

**SECTION 16780 [25450] – FINAL ES DESIGN – AV SOW  
AUDIO TECHNOLOGY SYSTEMS  
IN DISTRICT COURTROOM 530  
FEDERAL BUILDING – AKRON, OHIO**

**PART 1 - GENERAL**

**1.01 RELATED DOCUMENTS**

**A. INCLUSIONS**

1. All the provisions of the solicitation, attached documents, term contract (if applicable), General Terms and Conditions referenced by and included as a part of this solicitation as though bound herein.

**B. SCHEDULE B – SUBMITTED WITH PROPOSAL**

1. The Offerors are required to submit all basic price data in the exact format shown in the Schedule B (attached). All items offered must be listed in the Schedule. A unit price shall be submitted for each CLIN. All unit prices shall include handling, shipping, and delivery charges. If there is no price associated with a CLIN the designation "N/C" (no charge) shall be inserted in the applicable proposed model column and "0" into the applicable unit price column. The Schedule shall be completed by the Offerors and shall contain make/model of equipment and the unit price for all items to be purchased. The prices listed are to reflect any discounts offered. The Offerors shall complete the Schedule according to the following instructions.
2. CLIN 1000 - Equipment and Materials. The Government provides a generic description for the required equipment. The offerors shall list all the equipment and materials necessary for a complete and operational courtroom technology system. The offerors may add equipment and materials not specified but necessary for a complete and operational courtroom technology system in the provided areas of CLIN 3000. The offerors shall total the prices for all equipment and materials required for a complete courtroom technology system as shown on the Schedule.
3. CLIN 2000 - Total Labor. The offerors shall provide all the Labor costs associated with the installation, testing, and training for a complete courtroom technology system. Contract Line Item with its own Contract Line Item Number (CLIN) at the bottom of the equipment list that says that all other equipment, parts, and miscellaneous items not identified or included in another CLIN, but necessary to provide a complete and operational system in accordance with section C of the solicitation, the Specifications / Statement of Work (SOW).
4. CLIN 3000 - The offerors shall provide all other equipment, parts, and miscellaneous items not identified or included in another CLIN, but necessary to provide a complete and operational system in accordance with section C of the solicitation, the Specifications / Statement of Work (SOW). It is the responsibility of the offerors to include in this line item all items not identified elsewhere in order to submit a complete price for everything that is in the SOW. The Installer should review the Statement of Work (SOW) to determine all costs to complete the project as specified.
5. CLIN 4000 - Travel. The Offerors shall provide fixed prices for all the travel associated with completing the work required in the Statement of Work (IF TRAVEL IS REQUIRED). In determining the number of trips required the offerors should use past experience and the schedule provided with the SOW. If the contractor is a term contractor, the contractor may bill for travel per

Section H, Paragraph H.10.9.

6. Column 3 - Make/Model. The Schedule will include specific OEM product names and model numbers for the items the Technology Consultant has determined will meet the minimum requirements of the system. This in no way should be interpreted to imply the Government will only accept that make/model. In Column 4 the offerors may propose substitutions for the specific makes/models identified.
7. Column 4 - Substitution Make/Model. This column only needs to be completed if the offerors propose an item of equipment that is a different make/model than the item specified in Column 3. All proposed substitutions should be submitted with manufacturer's specification sheets in order that the Government can evaluate the functional equivalency of the proposed equipment to the specified make/model. The Government will evaluate and approve or disapprove any proposed substitutions.
8. Column 5 - Qty. The quantities shown in column 5 are provided as estimates to be purchased by the Government and are for evaluation purposes only and should be changed by the offerors only if necessitated by offering substitution equipment.
9. Column 6 - Unit Price. The purchase price for a single CLIN (i.e. quantity of one.)
10. Column 7 - Total Price. The total price for the specified quantity of a CLIN. This shall be derived by multiplying Column 5 (Qty) by Column 6 (Unit Price.)
11. Total Price for System. In the "Summary" section of the Schedule, the offerors shall add the total prices for the equipment for all courtrooms, the total price for labor, the total price for maintenance, and the total price for travel. This total will constitute the total price to be evaluated for task order award. If offerors are providing proposal under AOUSC term installation contract, awards will be made to the Technically Acceptable Lowest Price Offer. If offerors are providing proposal under different solicitation, check the attached solicitation.
12. Base Systems and Option Systems - This project has a not to exceed budget. Note that the scope of work notes base systems and option systems; the pricing for systems in ancillary spaces or for additive functions set out as optional line items subject to the availability of funds. Should the pricing come in over budget, or the technology budget be further reduced, setting the provided pricing schedules with options allows the court to reduce requirements through options rather than seeking a second round of pricing. This also allows the court to know the cost of the options they may wish to fund locally, if they can, if centrally held funds are not available.

C. INSTALLATION SCHEDULE: SUBMITTED WITH PROPOSAL

1. The Court shall provide an installation schedule. Offers shall submit statement of compliance with construction schedule starting from award through completion of the contract noting specific dates. If additional costs are required to provide the scope of work in the according to the schedule, note these costs in CLIN 3000. The Contracting Officer will have the right to reduce pay requests or final application of payment to the contractor in an amount equal to the equipment, travel costs and man-hours expended to complete the project on schedule and charged to the contractor. The Contracting Officer would then pay others in order to complete the scope of work on schedule from the funds withheld from the contractor if the contractor fails to complete the work as agreed to in the submitted installation schedule.

## D. DRAWINGS

1. The Drawings prepared for this Project are an outline to show where apparatus must go in order to harmonize with the building and installations of the various trades. Work must be installed in accordance with these drawings insofar as possible. The GSA installed infrastructure must be verified by the awarded contractor. All drawings shall be carefully checked during the course of bidding and construction. If discrepancies, errors, or omissions are discovered prior to or during the construction phase, notify the Contracting Officer (CO) and the Contracting Officer 's Technical Representative (COTR) immediately for interpretation or correction. Take necessary measurements and be responsible for same, including clearances for equipment that is to be furnished. The COTR shall reserve the right to make minor location changes of equipment where such adjustments are deemed desirable from an appearance or operational standpoint. Such changes will be anticipated sufficiently in advance to avoid extra work or unduly delay progress on the Project.

## 1.02 SUMMARY

### A. PROJECT INFORMATION

Court Contracting Officer (CO)  
UNITED STATES DISTRICT COURT, NORTHERN DISTRICT OF OHIO  
SHARON VANCE  
801 W. SUPERIOR AVENUE  
CLEVELAND, OHIO 44113  
SHARON\_VANCE@OHND.USCOURTS.GOV  
(216) 357-7073

Contracting Officer's Technical Representative (COTR)  
UNITED STATES DISTRICT COURT, NORTHERN DISTRICT OF OHIO  
DAVID ZENDLO  
801 W. SUPERIOR AVENUE  
CLEVELAND, OHIO 44113  
[DAVID\\_ZENDLO@OHND.USCOURTS.GOV](mailto:DAVID_ZENDLO@OHND.USCOURTS.GOV)  
(216) 357-7053

Court's Project Manager  
POLYSONICS CORPORATION  
405 BELLE AIR LANE  
WARRENTON, VA 20186  
STEVE BOUDREAU  
(540) 341-4988

CONTRACT NUMBER: OHND-18-01-10-DCA  
PROJECT NUMBER: 18-PS4-111

### B. PROJECT LOCATION

US DISTRICT COURTROOM 530  
FEDERAL BUILDING  
NORTHERN DISTRICT OF OHIO

C. RELATED DOCUMENTS

1. The requirements of this solicitation supplement the:
  - a. GSA's General Conditions and amendments. These documents are available upon request.

D. PERFORMANCE

1. Provide the labor, materials, equipment, appliances, services and transportation, and perform the operations in connection with the construction and installation of the Work. Work shall be as herein specified and as denoted on the accompanying solicitation documents.

E. CONSTRUCTION SCHEDULE

1. Court to determine. The Court's preference is to have the AV equipment racks(s) built and tested at the vender's site and not on-site. The SOW will include providing and installing new technology into an original courtroom(s).
2. Installation schedule dependent on courtroom availability

F. SCOPE OF WORK

1. Provide all the labor, materials, equipment, appliances, services and transportation for but not necessarily limited to provide a complete and operational systems.
2. The scope of work must be completed within the Government's construction schedule. Provide signed agreement to provide work according to the schedule. Any failure to provide the scope of work according to the schedule may result in delinquency of performance as defined in section 1.01, C. 1.
3. Provide signed test report performing to the minimum guidelines noted in this document before scheduling performance testing and final acceptance.
4. Unless noted otherwise on the bid documents, the work shall include everything necessary or incidental to complete the installation including receptacle plates, cables, racks, software, programming, connections, power supplies, interfaces, etc.
5. The contractor shall travel project to perform required coordination, perform field measurements, verify Government provided scope, perform testing, perform training and other visits to provide a complete and operational system, including Pre-construction Meeting/Survey, substantial completion, initial training, Final Acceptance, and final training.
6. The Contractor shall furnish all necessary coordination, documentation, submittals, and information to ensure that a proper system will be installed as intended and to meet the



Government's schedule.

7. The Contractor shall restore finish hardware to original condition including painting, wall, millwork, and ceiling modifications and attachments.
8. The Contractor shall provide comprehensive equipment list, cabling list and drawings noting all cables, connections, splices and pull boxes of system.
9. The AV Contractor shall test ALL hardware including video functions and accept them as operational at the time of project start. This includes all owner provided equipment including but not limited to speakers in the Gallery, Jury, Chamber Area, and the Cell Block. This would also include testing cabling from the AV equipment rack to the speaker locations.
10. The Government will provide conduit and AC power circuits (all AV circuits shall be in the same phase) with grounds. Such excluded equipment shall be coordinated with the Government and Government Representatives by the Contractor.
11. The Contractor shall provide ALL software (Compiled and Un-Compiled) (management specific and otherwise), final programming codes (e.g., AMX/Crestron), applications, etc for all equipment (IF APPLICABLE) such as control system, audio equipment, on CD-Rom.
12. The Contractor shall provide all manufacturer's' information, as-built drawings, test reports, user guides, etc. required for OEM and submittals on CD-Rom in Adobe acrobat format.
13. BEFORE commencement of work, the Contractor shall completely test and document the reused components. Provide written verification/report of proper functionality for reused components to the COTR.

### **1.03 INTERPRETATION OF CONTRACT DOCUMENTS**

#### **A. PRECEDENCE**

1. Precedence of project documents shall be as follows:
  - a. The CSI Specifications, DRAWINGS AND "Schedule B" SHARE the precedence, however all information cannot be represented completely in individual documents, rather the Drawings, Cost Schedule B and text documents provide the complete scope of work. Offerors are responsible to review the complete solicitation, including installation schedule, specifications and drawings to determine complete scope of work.
  - b. In the event of a discrepancy between the documents: Schedule B, CSI specifications and drawings, whichever is more stringent or calls for the highest quantity or quality of materials has precedence.
  - c. It is the responsibility of the offerors to include all items not identified elsewhere in line item provided on Schedule B in order to submit a complete price for everything that is in the SOW. Noted omissions in Schedule B must be brought to the attention of the CO and COTR prior to the time proposals are due so that an amendment to Schedule B can be issued.
  - d. It is the responsibility of the contractor to include all items for an operational system.

#### **B. OMISSIONS**

1. The omission of express reference to any parts necessary for, or reasonably incidental to, a complete installation shall not be construed as a release from providing such parts.

2. Noted omissions in Schedule B must be brought to the attention of the CO and COTR prior to the time proposals are due so that an amendment to Schedule B can be issued.

#### C. ANCILLARY AND ACCESSORY ITEMS

1. No exclusion from, or limitations in, the language used in the drawings or specifications shall be interpreted as meaning that the accessories necessary to complete any required system or item of equipment are to be omitted.

#### D. DRAWINGS

1. The drawings of necessity utilize symbols and schematic diagrams to indicate various items of work. Neither of these have any dimensional significance nor do they delineate every item required for the intended installations. The work shall be installed in accordance with the intent diagrammatically expressed on the drawings and described in these specifications. No interpretation shall be made from the limitations of symbols and diagrams that any elements necessary for complete work are excluded.
3. The Government shall reserve the right to make minor location changes of equipment where such adjustments are deemed desirable from an appearance or operational standpoint. Such changes will be anticipated sufficiently in advance to avoid extra work or unduly delay progress on the Project.
4. Contractor will provide necessary measurements and be responsible for same, including clearances for equipment that is to be furnished.

### 1.04 REFERENCE MATERIALS AND/OR CODES

#### A. ORDINANCES

1. All work shall conform to all federal, state, and local ordinances and building official requirements.

#### B. BUILDING CODES

1. All work shall conform to all state and local building codes and the following:  
National Electrical Code (NEC)  
National Fire Protection Association (NFPA)

#### C. UL LISTING

1. All material and equipment shall be listed, labeled, or certified by Underwriter's Laboratories, Inc. where such standards have been established.

#### D. FCC APPROVAL

1. The system shall be approved for direct interconnection to the utility services under Part 68 of FCC rules and regulations. Those systems that are not FCC approved or utilize an intermediary device for connection will not be considered. Provide FCC registration number of system being proposed with submittals.

## **1.05 ON-SITE PRECONSTRUCTION MEETING**

### **A. GENERAL**

1. Upon Notice of Award and prior to initialization of the project the COTR will facilitate a Pre-construction project Meeting on site. Any costs associated with this meeting should be included with your proposal. The agenda of the meeting will cover:
  - a. Standard and general policies regarding contractors working on Government property.
  - b. Security Clearance request format and procedure.
  - c. Review detailed scope of work.
  - d. Review of Project Submittal requirements, dates and format.
  - e. Review and update the overall project schedule and how this scope of work interfaces with that schedule.
  - f. Review of Project Schedule Submittal requirements and format.
  - g. Contractor to survey, verify project conditions, verify exact dimensions and submit required site visit report document noting findings, omissions, and items noted in the design documentation.
  - h. Contractor shall provide – Name, Address, and Social Security information on all installers for background security checks.

## **1.06 PROJECT SUBMITTALS**

### **A. GENERAL**

1. Provide complete Pre-construction site visit report noting any deviations, omissions and any other issues that impact the contractor's completion of the project. Report including conduit/wiring study, note any deficiencies, additional requirements and information that are required to provide a complete system as noted in the bid documents and subsequent contract documents. Include a revised project schedule to adjust for any changes throughout the project.
2. Submittals must have written approval of the Government and the Government Representatives prior to purchase of equipment, commencement of work, fabrication, and installation. Submit all information specified. The Government or any Government Representative may request additional information. Submit two identical copies of all submissions except for samples required in bid documents. Information shall be transmitted via E-mail in WordPerfect or Word, Excel and or Schedule. Drawings shall be provided in AutoCAD and Adobe Acrobat formats. Written copies shall be provided to COTR (2 copies) and CO (1 copy).
3. Provide complete shop drawings and submittals for all systems specified within 30 days of notice of award or actual award of contract whichever occurs first. Submit all information specified. The Government or any Government Representative may request additional information. Information shall be transmitted via E-mail in Adobe Acrobat, WordPerfect, Word, Excel and or Schedule. The COTR will review and return submittals and shop drawings according to the CSI. Failure to obtain submittal approval within scheduled time noted in CSI and or where the delay is due to the poor performance of the contractor, may be cause for penalties and or cancellation of the contract without penalty of the Government.
4. The Contractor should not consider the CO and COTR's review of submittals to be exhaustive or complete in every detail. Approval of submittals, including substitutions, indicates only the

acceptance of intent to comply with general design or method of construction and quality as specified. The functional requirements, operations, arrangements, and quantities must comply with the contract documents unless changes are specifically approved in writing. Submittal approval does not relieve the Contractor of responsibility for errors in dimensions, details, sizes, fir, etc. or coordinating items with actual building conditions. Contractor's responsibility for error and omissions in submittals is not relieved by the CO and COTR review of submittals.

5. Review complete specification for all submittal requirements, including product-specific submittals noted in Part 2.
6. Submittals and shop drawings will be provided in a single package, multiple partial submittals are not acceptable.
7. Submittals, which in the Court Project Manager and COTR's opinion, are incomplete, deviate significantly from the requirements of the Project Specifications, or contain numerous errors will be returned without review for rework and are to be re-submitted.
8. If submittals and/or drawings are rejected, or approved with noted changes and re-submittal required, the Contractor will correct the documents as required and resubmit within fourteen (14) days at no additional cost to the government.
9. The Contractor will not fabricate products, begin work, or submit invoices for the scope of work defined in the project documents until return of submittals and shop drawings with the CO and COTR's acceptance.

#### B. SCALED DRAWINGS (Shop Drawings)

1. Each drawing shall have a descriptive title and all subparts of each drawing shall be completely described. All drawings shall have the name of the project, CO and COTR's name and address, consultant, and electronics contractor in the title block.
2. Cabinets and custom millwork
  - a. Provide complete scaled elevation drawings of all work in or near custom millwork and equipment racks with equipment identification number.
3. Primary Cable Paths, Power and Device Locations
  - a. Provide marked drawings (can use GSA construction drawings) detailing projected primary cable paths and locations of all plates exposed cables, etc. in quantities noted in the general requirements. These drawings will be utilized for "as-built" submittals with cable numbers noted at the end of the project. Contractor will coordinate the layout of equipment on the backboard with the other Contractor(s)
4. Assembly, Supports, and Panel/Plate Layout
  - a. Provide diagrammatic representation of all assemblies, i.e. connector panel and/or plate layout. Identify the components that make up the assembly or are used on the panel/plate. For connector panel or plate, indicate identification location and methodology. Floor, wall and millwork plates are the based on information gathered during the pre-construction site survey by the contractor. Contractor will coordinate the layout of cabling and equipment on the backboard with the other Contractor(s)

#### C. MANUFACTURERS PRODUCT DATA

1. Manufacturer Cut Sheets for submittals (not OEM manuals)

- a. Provide complete sets of a project material list with manufacturer specification sheets for each manufactured cable and device utilized within the system in quantities noted in the general requirements (ONLY WHEN AN ALTERNATE DEVICE IS PROPOSED OR SUBSTITUTED). The Court Project Manager and COTR will use these sets in determining that all products listed are being supplied as required.
2. Samples
  - a. Provide samples of the following:
    - 1). Any custom plates.
    - 2). All finishes of plates, or custom assemblies. (These may be manufacturer cuts sheets indicating the various colors and finishes available).
    - 3) Equipment identification tag material, labeling method, and numbering method
    - 4) Cable labeling material, labeling method, and numbering method
    - 5) Faceplate labeling material, labeling method, and numbering method.
    - 6) Any additional items noted by the COTR.

## **1.07 QUALITY ASSURANCE**

### **A. GENERAL**

1. Unless otherwise noted as "reused," "OFE" or "CFE," all cable and materials required for installation under these specifications shall be new (less than 1 year from date of manufacture) and without blemish or defect.

## **1.08 ACCEPTABLE MANUFACTURERS**

- A. These specifications are based on products manufactured by or for specific manufacturers. It is not the intent of these specifications to limit or restrict submission of proposals for products by other manufacturers but to set a baseline of operational functions, which all proposals must meet. If substitutions or specified models are no longer available, it is the responsibility of the contractor to provide submission of technically acceptable product or latest model.

## PART 2 - PRODUCT & SERVICES

### 2.01 ELECTRONIC SYSTEMS CABLING

1. **EXISTING** wiring to be re-used where possible, unused wiring is to be abandoned in place. **EXISTING** custom AV plates and audio connections at **Attorney table** and floor box locations (TA1/2/FA1/2). Notify court of any nonworking connections. Provide **NEW** headphone jack in existing plate with existing cable run.

**EXISTING** Cable should be concealed and neatly managed. Coordinate existing cable path with court. Site inspection should be made to coordinate with existing conditions. See drawings and Schedule B (detailed itemized schedule) for complete SOW.

2. **EXISTING** wiring to be re-used where possible, unused wiring is to be abandoned in place. **EXISTING** custom AV plates and audio connections at **Judge's** location. Notify court of any nonworking connections. Remove any unused audio connectors and abandon cabling in place as directed by the Court. Provide **NEW** headphone jack in existing plate with existing cable run.

**EXISTING** Cable should be concealed and neatly managed. Site inspection should be made to coordinate with existing conditions. See drawings and Schedule B (detailed itemized schedule) for complete SOW.

3. **EXISTING** wiring to be re-used where possible, unused wiring is to be abandoned in place. **EXISTING** custom AV plates and audio connections at **Clerk's** location. Notify court of any nonworking connections. Remove any unused audio connectors and abandon cabling in place as directed by the Court.

**EXISTING** Cable should be concealed and neatly managed. Site inspection should be made to coordinate with existing conditions. See drawings and Schedule B (detailed itemized schedule) for complete SOW.

4. **EXISTING** wiring to be re-used where possible, unused wiring is to be abandoned in place. **EXISTING** custom AV plates and audio connections at **Evidence Presentation Station** locations.

**EXISTING** Cable should be concealed and neatly managed. Site inspection should be made to coordinate with existing conditions. See drawings and Schedule B (detailed itemized schedule) for complete SOW.

5. **EXISTING** wiring to be re-used where possible, unused wiring is to be abandoned in place. **EXISTING** custom AV plates and audio connections at **Witness** location. Notify court of any nonworking connections. Remove any unused audio connectors and abandon cabling in place as directed by the Court.

**EXISTING** Cable should be concealed and neatly managed. Site inspection should be made to coordinate with existing conditions. See drawings and Schedule B (detailed itemized schedule) for complete SOW.

6. **EXISTING** wiring to be re-used where possible, unused wiring is to be abandoned in place. **EXISTING** custom AV plates and audio connections at **Reporter** location. Notify court of any nonworking connections. Remove any unused audio connectors and abandon cabling in place as directed by the Court. Provide **NEW** RJ45 jack in existing plate with **NEW** CAT6 cabling for USB

extender. Site inspection should be made to coordinate with existing conditions. Provide **NEW** 10kohm linear volume control in existing headset box re-use existing cable run.

**EXISTING** Cable should be concealed and neatly managed. Provide **NEW** RJ45 jack in existing plate with **NEW** CAT6 cabling for USB extender. Site inspection should be made to coordinate with existing conditions. See drawings and Schedule B (detailed itemized schedule) for complete SOW.

7. **EXISTING** wiring to be re-used where possible, unused wiring is to be abandoned in place. **EXISTING** custom AV plates and audio connections at **Jury Microphone Location**. Notify court of any nonworking connections. Remove any unused audio connectors and abandon cabling in place as directed by the Court.

**EXISTING** Cable should be concealed and neatly managed. Site inspection should be made to coordinate with existing conditions. See drawings and Schedule B (detailed itemized schedule) for complete SOW.

8. **EXISTING** wiring to be re-used where possible, unused wiring is to be abandoned in place. **EXISTING** custom AV plates and audio connections at **Main Rack** location to support AV system in courtroom and ancillary areas. Verify, Test, and Label **EXISTING** Cable.

**EXISTING** Cable should be concealed and neatly managed. Coordinate cable path with court. Site inspection should be made to coordinate with any existing devices. See drawings and Schedule B (detailed itemized schedule) for complete SOW.

9. **EXISTING** wiring to be re-used where possible, unused wiring is to be abandoned in place. **EXISTING** custom AV plates and audio connections at **Lectern** locations.

**EXISTING** Cable should be concealed and neatly managed. Site inspection should be made to coordinate with existing conditions. See drawings and Schedule B (detailed itemized schedule) for complete SOW.

10. **EXISTING** wiring to be re-used where possible, unused wiring is to be abandoned in place. **Speaker** locations to support AV system in courtroom and ancillary areas.

**EXISTING** Cable should be concealed and neatly managed. Site inspection should be made to coordinate with existing conditions. See drawings and Schedule B (detailed itemized schedule) for complete SOW.

11. Provide all engineering, documents, layouts for submittals as noted in this document and attached contract.

12. Test all cabling, connectors and other items necessary for complete cabling system to support AV systems in this room. Site inspection should be made to coordinate new equipment and cable locations with any reused equipment, or infrastructure. See drawings and Schedule B (detailed itemized schedule) for complete SOW. Velcro ties or strips shall be used for easier access and cable management. Coordinate cable labels with Court.

## 2.02 PERMANENT AUDIO EQUIPMENT:

13-14. Provide and new install fixed I/O digital signal processor with the ability to be externally controlled such as [3] Tesira FORTE AVB VT plus any additional cards that are required for functionality. The DSP shall be SIP compliant. Refer to drawings for input/output configuration. Provide with AVB network switch such as [1] MOTU AVB Switch.

15-19. Provide and install new four-channel amplifier with 70V output to supplement existing audio system such as [1] QSC CX204V. Speaker zones shall be reconfigured as indicated on drawings.

In addition, provide and install new headphone amplifiers, and audio distribution amplifiers such as RDL ST-SH2/ PS-24/ RU-DA4D/ MB-1.

20-22. Verify and test existing ceiling speakers over the Jury, Well, and Gallery areas to ensure speakers are in proper working order. Notify court of any nonworking or damaged speakers. Speaker zones shall be configured (zoned) and connected to amplifier as indicated on drawings.

23-24. Verify and test existing ceiling speakers in chamber areas to ensure speakers are in proper working order. Notify court of any nonworking or damaged speakers and volume controls. Speaker zones shall be configured (zoned) and connected to amplifier as indicated on drawings.

25-31. Provide and install NEW floor-standing equipment rack with, roller truck, rear mounting rails, blank panels, power distribution unit(s) such as Middle Atlantic [1] ERK-2725 / [1] CBS-ERK-25R / [1] ERK-RR27 / Middle Atlantic Blank panels / [1] ETA PD11LVSP / [1] ETA PD11P / [2] Middle Atlantic PDT-2X1015T. Connect new rack to existing controllable power sequencer. Ensure rack properly starts up from control system command with now pops or other noise on start up.

32-36. Verify and test existing infrared system to ensure system is in proper working order. Notify court of any nonworking or damaged system components. Test system for coverage throughout the space. Confirm system Configuration with Court.

37-38. Provide, connect, and install [1] Gefen USB 2.0 LR Port Extender. The Court will provide computer, sound card, and FTR software a later time. All components above shall be compatible with Microsoft Windows 7 Operating System. Configure and test to ensure the correct audio channels are assigned and are present at the plate. Channels shall be assigned as follows:

Channel 1: Active Judge and CRD microphone

Channel 2: Active witness microphone

Channel 3: Defense and presenter cart microphones

Channel 4: Prosecution microphones, wireless, evidence, tele and video conferencing audio, and all TIPS audio channels.

The contractor is not responsible in providing the FTR Gold Software in this Scope of Work.

39-43. Provide and install four-channel secure wireless microphone system complete with encryption and two-way audio function including charger, receiver, three clip-on microphone transmitters with one hand held transmitter, and one wireless access point such as [1] Shure MXWAN14 4-Channel audio interface [1] Shure MXWAPT4 4-Channel access point, [1] Shure MXWNCS4



4-Port charger, [1] Shure MXW2/SM58 Handheld Transmitter, [3] Shure MXW1 Bodypack Transmitter. Test system for coverage throughout the space and adjust transmitter/receiver power to the lowest setting while still maintaining full coverage in the entire courtroom. Coordinate programming with the Court to ensure proper set up.

Wireless microphone system shall be used as part of the two-way TIPS for remote interpreting as well as for general audio reinforcement. A matrix function will be required in the Crestron control system code to provide this flexibility.

44. Provide programming for the audio and control system as follows:

**Audio:**

All existing functionality, zoning and features are to be maintained. Contractor shall test and verify proper operation of all existing audio functions prior to work.

Existing speaker zones to be maintained, or if possible, reconfigured for mix/minus to increase intelligibility. Routing of teleconference, duplex TIPS operation, and/or ALS system to be controlled by a simplified version of the audio matrix currently employed.

1. Assisted Listening & FTR Recording

- a. Four (4) channels mixed as specified in 2.02, #41
- b. Provide audio output for infrared Assistive Listening System (ALS).

2. Audio Conferencing - Video Conferencing Audio

- a. Full duplex communication from all courtroom audio sources.
- b. Far end audio signal played through PA sound reinforcement loudspeakers, IR system and court reporter and all headphone outputs.

3. Headphone connections (independent of court reporter)

Where employed at the rack, existing analog volume control potentiometers are to be removed. All level controls to be digitally controlled by new DSP.

**Control System:**

1. Contractor to provide DSP programming to match existing functionality. New DSP system shall be integrated with, controlled by, existing Crestron control system.

2. The Contractor shall provide all programming of control panel layouts. Programming shall include use of graphics and icons for ease of use by the Court. Button functions shall track on multiple panels to always indicate the true status. Source code for existing Crestron control system will be modified to control new DSP audio.

3. Provide power up sequencing as defined. All power up functions listed below and timing sequences are approximate and shall be verified and reprogrammed as required for shortest timing possible. This will occur during project engineering and programming stages, based upon actual equipment used and according to Court preferences.

- a. When the System Shutdown button is engaged, the current audio matrix level and mute settings shall be retained and a "blank" matrix shall be called to prevent audio system popping and equipment damage.
- b. When the System Shutdown button is engaged, power shall turn off after 15 seconds.
- c. When the System Shutdown button is engaged, turn all microphone phantom power off in order to extinguish the power lights on the microphones.
- d. When the Power On sequence is selected, power shall turn on immediately.

- e. After the system has stabilized, the control system shall call the normal room configuration audio matrix preset routing all nominal inputs and outputs.
- f. The matrix settings shall retain the last used level settings and mute conditions and restore those to system. Note that these may not be the same settings to be called when the Master Reset is called.

4. Provide Master Reset function in code so that users can (at any time) reset the system to the last calibrated state as intended by the Contractor. This reset state shall NOT be automatically initiated at each power-up sequence. Each and every controlled device shall have action or actions that are called under this function. All reset functions listed below and timing sequences are approximate and shall be verified and reprogrammed as required for the shortest timing possible. This will occur during project engineering and programming stages, based upon actual equipment used and according to Court preferences. The following sequence actions shall commence when the Master Reset sequence is selected in the order listed:

- a. All microphones shall be muted.
- b. The control system shall call a "blank" preset in the audio matrix in order to disconnect all inputs from routing to any output.
- c. Audio conference hybrid shall be placed on-hook.
- d. The bench conference mode shall be turned off.
- e. All mixers shall be reset to the original stored, calibrated, and approved settings for all mixer functions.
- f. Out of room audio shall be muted by default
- g. Chambers audio feed may be set to default on or off based on judicial preference.
- h. USMS audio output shall be muted by default
- i. All microphones shall be un-muted
- j. The transcription playback input shall be muted.
- k. Videoconference / audio tele-conference systems shall be placed on-hook and muted.
- l. The control system shall call the normal room configuration audio matrix preset routing all nominal inputs and outputs.
- m. Control panels shall return to home page.
- n. Audio to streaming appliances shall be muted by default

5. Maintain automatic system shutdown feature. System shall commence the shutdown feature each night of the week at 9:00 pm local time. The system shall automatically adjust for daylight savings time twice yearly.

6. Audio system control configuration. All microphone and program audio outputs shall be routed as listed below. Configure and program the control system and matrix mixer according to the overall design of the system. This includes but is not necessarily limited to the following parameters for the loudspeakers.

- a. Wireless Mic On/Off: shall mute the Wireless Microphone inputs from the receiver at the matrix mixer when set to "off". When set to "On" the system shall open the Wireless Microphone inputs. The default state for this control on system start-up shall be "Off".
- b. Judge Mic/Lav: shall mute the Judge's Microphone input and open the Judge's Lavalier input when set to "Lav". When set to "Mic" the system shall open the Judge's Microphone input and mute the Judge's Lavalier input. The default state for this control on system start-up shall be "Mic".
- c. Witness Mic/Lav: shall mute the Witness' Microphone input and open the Witness' Lavalier input when set to "Lav". When set to "Mic" the system shall open the Witness' Microphone input and mute the Witness' Lavalier input. The default state for this control on system start-up shall be "Mic".
- d. Any boundary microphones shall have a default set to "Off".

- e. "Out of Room" On/Off function shall be provided to stop audio from traveling outside the visible perimeter of the courtroom and chambers. When "Out of Room" is off, no feeds shall be routed to the USMS, streaming server, or (in Cleveland locations only) holding cell audio feed. When function is enabled, audio will mute on sidebar. Independent of Chambers On/Off.
- f. "Chambers On/Off" function shall allow sound to be switched on or off to chambers independent of "Out of Room" function.
- g. Microphone base mute programming: program local control buttons on all boundary type of microphones for push-and-hold to mute mode. Program all attorney table microphones for push-and-hold to mute mode. Program all remaining microphones for push-on/push off toggle.
- h. Overall Gain: shall be readily accessible control and shall control the gain of all loudspeaker outputs simultaneously. Control of noise masking output level shall be provided separately. Where direct outputs have been provided to drive powered loudspeakers, direct outputs shall also track with overall room gain and with room mute functions.
- i. Individual Gain shall be provided for all input and output channels. These shall control the gains of each of the individual inputs and outputs separately. These include all individual line and microphone level sources and individual outputs such as loudspeaker zones, individual recording channels, and audio/video conference send and receive. All settings to be controlled under the reset function.
- j. Telephone Interface: Provide programming to control system. Maintain XPanel/Adobe Air control of telephonic interface functions, including but not limited to caller volume control, mute, speed dial, call setup, number entry clear, flash, and calibrate. Provide dialer for each phone line provided.
- k. Telephone Interface IR/Broadcast Display: When any phone dialer screen is active, show "IR" and "PA" switch on screens for all lines selected for use with any interpreter mode. When any phone line is set for standard audio conference, the dialer screen for that telephone line shall not display the "IR" or "PA" options. Default setting for incoming sound should be set to route to the PA system only. All interpreter and general tele-conference mixed to reporter headset no matter the IR or PA destination.
- l. Telephone Hybrid Incoming Calls: Maintain interface setup control on control panels so that the system accepts incoming calls but does not ring audibly within the courtroom. Duplicate current audio controls and functions Provide control programming such that the bench area control screens flash an indicator that an incoming call is being received. The visual alert on the control screen(s) shall graphically cover 50% of the display area and flash in contrasting images to alert Court staff as to call status. Mute all inbound and outbound audio when mute function is enabled and when "Bench Conference" is enabled.
- m. Video Conference audio: Duplicate current audio controls and functions.
- n. DSP Interface: Provide remote control of automatic microphone mixer to integrated control system. Provide protocol translation as required for complete control of all mixer functions and all individual input level controls via integrated control system. Provide overall gain that is readily accessible to control gain of all outputs simultaneously. Provide individual gain control of each input and microphone on an easily accessible page. Provide access to each input and output control on control panels under password/code protection.
- o. Bench Conference: Provide gain control to bench conference system so that when activated, control system will adjust gain of noise masking system and input volume of boundary and (active) judge microphone. Bench conference gain control shall be programmed as a steady ramp up and down. Judge's Mic/Lav and boundary microphone both to be mixed to reporter headset and FTR record feed.
- p. Maintain all existing speaker locations and provide independent gain control.

Provide up to two iterations of system/component programming at no additional cost.

The Court to retain ownership of all compiled/un-compiled source code as well as platform specific interface control programs for all components.

45. Test audio wiring to plates. Refer to audio schematic for new connections/cabling. Verify exact configuration in the field at pre-installation site visit and notify the government immediately of any deviations.

## SEE COST SCHEDULE & DRAWINGS FOR DETAILED SCOPE OF WORK

### TRAVEL, FIXED PRICE LUMP SUM

Provide fixed prices for all the travel and lodging (if required) associated with completing the work required in the Statement of Work, including all inspections, coordination, training and testing trips. In determining the number of trips required, the offerors should use experience and the schedule provided with the SOW.

### **2.03 WARRANTIES**

- A. Installation of each system in its entirety shall be installed per manufacturer's specifications and warranted by the Contractor for a period of one (1) year from date of written FINAL acceptance to meet all performance requirements outlined herein. Warranties may not be pro-rated.
- B. Warranties include all modifications and change orders to this contract but do not include products or services purchased outside of this contract.
- C. During warranty period, no charges shall be made for any labor, materials, equipment, appliances, services, travel, and transportation during this period to maintain performance and functions.
- D. During the warranty period, the Contractor shall respond with remedy to a trouble call within twenty-four (24) hours after receipt of such a call, and provide a 24-hour service phone number.
- E. During training, The Court Project Manager must be provided with warrantee contact number, contact procedure. This information is required with the substantial and final completion documentation.
- F. Service department employees and contractors to have security clearance BEFORE final acceptance to allow unsupervised access in Court facilities. The Contracting Officer's Technical Representative must be provided with contact number, contact procedure, and list of service technicians with security clearance.

### **2.04 SUPPORTS**

1. Provide and install brackets, braces, and supports as required. Minimum fastening and/or support safety factor shall be at least three (3). Design shall be to the approval of the COTR.

### **2.05 PAINT / FINISH**

1. All supporting structures and enclosures supplied by the contractor not having a standard

factory paint finish shall be painted in a manner approved by the COTR.

## **2.06 PAINT / FINISH COLOR**

1. Provide, as may be required, custom color and/or finish for any equipment or materials supplied which are exposed to public view. Color and finish of all such equipment or materials shall be submitted to the Government for approval. This does exclude equipment or materials where standard colors and finishes are specified herein, unless otherwise noted.

## **2.07 BLANK AND CUSTOM PANELS**

1. Finish of blank panels and/or custom assembly panels utilized for termination and/or interconnection, as part of this system shall be black.
2. In addition, provide blank plastic panels finished in matte (or satin) black to close off all spaces around the source equipment in the distribution room racks. These panels shall have cutouts that provide access to the source machine and its controls. Match each panel to the device it is covering in the racks.

## **2.08 MARKINGS**

1. Switches, connectors, jacks, receptacles, outlets, cables, and cable terminations shall be logically and permanently marked in a manner approved by the COTR. Custom panel nomenclature shall be engraved, etched, or screened. Marking for these items are purposely detailed in the drawings to ensure consistency and clarity. Verify any changes in working type size, and/or placement with the COTR prior to marking. Mount on the custom rack panels as described above a designation of each source machine, which correlates to the system architecture.
2. Cable labels shall be laser printed cable labels with description of function (ex. Judges Lav Mic). Descriptions shall be in English and cable labels shall be permanently adhered to the cable with clear heat shrink so that label is readable.

## **2.09 ENVIRONMENT**

1. The equipment specified herein is designed to operate in environments of normal humidity, dust, and temperature. Protect equipment and related wiring where extreme environmental conditions can occur.

## **2.10 REFERENCE STANDARDS**

NOTE: US Judicial facilities are unique facilities and do not specifically conform to all national standards, they are not commercial buildings that must flex with meet specific requirements. Requirements are available from "US Courts Design Guide" and "Courtroom Technology Manual" available upon request. Where practices noted within this specification do not adhere strictly to the national standards, it has done so for a specific purpose related to educational facilities. Consult with CO and/or COTR if questions arise.

1. The standard references for the layout and construction of the system shall be:

### **A. GENERAL**

- TIA/EIA-568- Commercial Building Standard for Telecommunications Wiring
- TIA/EIA-569- Commercial Building Standard for Telecommunications Pathways and Spaces.
- TIA/EIA-606- Administrative Standard for the Telecommunications Infrastructure of Commercial

	Buildings.
TIA/EIA-607-	Commercial Building Grounding/Bonding Requirements.
BICSI-TDM-	Manuals-Building Industry Consulting Service International-Telecommunications Distribution Methods Manuals.
ANSI-	American National Standards Institute
UL Listed-	Underwriter's Laboratories Listed
UL Certified-	Underwriter's Laboratories LAN Cable Certification Program.
NEMA-	National Electrical Manufacture's Association.

#### B. AUDIO

Handbook for Sound Engineers  
The New Audio Cyclopedia  
(Howard W. Sams, Indianapolis, Indiana 1987)  
Davis  
Sound System Engineering  
Second Edition  
(Howard W. Sams, Indianapolis, Indiana 1987)

#### C. VIDEO

National Association of Broadcasters  
Engineers Handbook

#### D. FIBER OPTICS

Refer to the fiber optic cable manufacturers design guide:

i.e. SIECOR

Siecor Universal Transport System (UTS) Design Guide, Siecor Corp., 1988  
Brochure #CC-110

Also refer to the following standards committees:

\* ANSI: Proposed Fiber Distributed Data Interface (FDDI) Physical Media Documents

\* Institute of Electrical & Electronic Engineers (IEEE) 802.8

\* Electronic Industries Association (EIA) Committees:

TR4 1.8.1: Working Group on Commercial & Industrial Building Wiring Standard

## PART 3 - EXECUTION

### 3.01 GENERAL

Perform this work in accordance with acknowledged industry and professional standards and practices, existing building conditions, and as specified herein. Provide and install all materials, devices, components, and equipment for complete, operational systems.

A. Maintain a competent supervisor and supporting technical personnel, acceptable to the Government, during the entire installation. Change of the supervisor during the project shall not be acceptable without prior written approval from the CO.

C. Maintain a qualified and competent workforce with prior experience and knowledge of the systems and work contained within the contractors' scope of work. Additionally, maintain a workforce of sufficient size to execute the contractor's scope of work within a time line that matches up to the overall project schedule or the COTR's schedule for this project. The specific completion date of the overall project and this specific scope of work will be defined at the Pre-Construction meeting.

D. Coordinate all efforts with those of related trades. In the event of any conflicts, delayed or improper preparatory work by others, notify the CO and the COTR. The CO and COTR's decision will be binding. Verify all field conditions.

**3.02 CONDUIT, RACEWAY, and BACKBOXES**

A. The Premise Cabling Contractor (GSA) shall be responsible for the completed conduit, raceway, and back box installation for the Premise Wiring Systems. The completed installation shall conform to the following sections (3.02, 3.03, and 3.04).

1. INSTALLATION

- a. Where installed exposed in electrical closets, conduits shall be parallel with or at right angles to walls or ceilings and shall be adequately supported from walls or ceilings by means of approved galvanized iron clamps or hangers. Conduit connections to equipment racks shall be insulated.
- b. Conduits stubbed above ceiling line shall be turned in toward the room that will be serviced by the cables pulled into that conduit/box.
- c. Only raceway that is specifically designed for surface shall be mounted on the surface of walls. No conduit normally installed in the interior of walls shall be acceptable for surface mount applications.

2. CONDUIT SIZE

- a. Minimum size conduit shall be 3/4 inch. All conduits to be sized for maximum 40% fill or less if required by code.

3. CONDUIT SEPARATION

- a. THESE GROUPS MUST NEVER BE INTERMIXED IN A GIVEN CONDUIT!
- b. Low Voltage Systems wiring is divided into wiring groups according to their nominal voltage levels and cable types. Those groups are:  
 GROUP A - extremely sensitive wiring (0 to 100mv).  
 GROUP B - moderately sensitive wiring (1v to 10v).  
 GROUP C - Non sensitive wiring (10 to 70v).  
 GROUP D - AC Power Wiring.  
 GROUP E - Fiber Optic cables.
- c. Intra-System Separation  
 Minimum conduit separation between conduits carrying wiring of different groups is as follows (90 degree crossings in close proximity are acceptable):

	GROUP	A	B	C	D	E
A	adjacent	12"	12"	12"	adjacent	
B		adjacent	6"	6"	adjacent	
C			adjacent	6"	adjacent	
D				adjacent	adjacent	
E					adjacent	

d. Electrical Service Separation

- 1) Minimum conduit separation between conduits carrying wiring of different groups, as defined above, and other electrical service conduit is as follows: (All fiber optic conduits, Group E, may be adjacent to other electrical service conduit).

OTHER SERVICES	A	B	C

Dimmer Controlled Lighting	24"	12"	6"
220/440V circuits	12"	6"	6"
All other services SCR (controlled or switched)	24"	12"	6"

### 3.03 ELECTRICAL POWER

#### A. GROUNDING

1. Review and coordinate electrical power system installation including grounding, with the electrical contractor to ensure proper operation of the system. The project Electrical Contractor will provide a TIA/EIA compliant grounding system in the head end room.

#### B. VERIFICATION

1. Verify that all AC power circuits designated for the system are properly wired, phased, and grounded. Report in writing any discrepancies found to the Project Architect for corrective action.

### 3.04 EQUIPMENT RACK

A. Provide distribution of electrical power within the equipment racks with a minimum of one spare AC receptacle for each four in use per branch circuit or a minimum of two spare AC receptacles per branch circuit, whichever is greater. Power is available on the wall. Where applicable, extension of those circuits by the project's electrical contractor will be coordinated by and paid for under this contract.

### 3.05 BOXES

#### A. MOUNTING

1. With the exception of portable equipment, all boxes, conduits, cabinets, equipment, and related wiring shall be held firmly in place and the mounting shall be plumb and square. All boxes shall be rigidly and securely mounted to building structure. All boxes shall be installed so that wiring contained in them is accessible. Install blanking devices or threaded plugs in all unused holes.

#### B. WIRING

1. Wiring groups and circuits shall be isolated as indicated herein. Common pull or junction boxes shall be avoided. Where deemed necessary and approved, they shall be barriered.

#### C. CLEANING

1. Clean all box interiors thoroughly before installing plates, panels, or covers.

### 3.06 WIRING METHODS & PRACTICES

#### A. SUPERVISION

1. Installation of all audio, video, control, and/or fiber cable to be provided under this scope of



work is by this contractor. Supervision to include, but not be limited to ensuring proper:

- a. Pulling Tensions
- b. Quantities
- c. Types
- d. Lengths
- e. Routing
- f. Wire Group Separation
- g. Identification

## B. IDENTIFICATION

1. All wires shall be permanently identified at each wire end utilizing a self-laminating wire or cable marker comprised of a white label with clear overlamine area, in a manner approved by the Court Project Manager and Court's Technical Consultant.

## C. TERMINAL BLOCKS

1. All terminal block connections shall be readily accessible. Not more than one wire connected to one terminal. Spare terminal blocks, equivalent to 10% of those in actual use shall be provided.

## B. SPLICING

1. Splicing of cables is not permitted between terminations.

## C. PULLING CABLE

1. Do not pull wire or cable through any box fitting or enclosure where change of raceway alignment or direction occurs; do not bend conductors to less than recommended radius. Employ temporary guides, sheaves, rollers, and other necessary items to protect cables from excess tension, abrasion, or damaging bending during installation. Care shall be taken not to bend, crush, or kink cables.

## D. CABLE TIES/VELCRO STRIPS

### 1. Building Locations

a. Comb straight and form in a neat and orderly manner all conductors in cable support rings or other types of open support systems, providing circuit and conductor identification. Tie as required using plenum rated T&B "Ty-Raps" (or equivalent) of appropriate size and type. Limit spacing between ties to six inches. Cable tie shall not compress the jacket. As mentioned in this document the use of "Velcro" strips is preferred over the use "ty-wraps".

### 2. Equipment Cabinets or Racks

a. Comb straight and form in a neat and orderly manner all conductors located within equipment cabinets, located in the head end room or remote locations, and wiring harnesses in the head end room. Tie as required using Velcro cable ties of appropriate type and size. T&B "Ty-raps" are not acceptable.

## E. SERVICE LOOPS

1. Provide ample service loops at each termination so that plates, panels, and equipment can be demounted for service and inspection. Provide the following as a minimum:

- a. Outlet box: Eighteen (18) inches from wall surface to jack.
- b. Termination panel: Four (4) inches behind termination panel from last cable tie to jack.

- c. Fiber terminations: Eighteen (18) inches of service loop coiled and stored in junction box (minimum size 4"x4" box). Take care not to exceed bend radius of fiber.

#### H. NON-CABLE TRAY INSTALLATION

1. All cable installations which are not supported by a cable tray or conduit system and where educational technology system cables are allowed to be placed loosely in the ceiling must follow the TIA/EIA standard methodology as noted in TIA/EIA 569 - Part 4.6 Ceiling Pathways. Specifically, sections 4.6.1 General, 4.6.2 Design Guidelines, and 4.6.5 Cable Support. Those sections are paraphrased herein (the contractor will be familiar with the specifics of these sections and install their cables in accordance with the standard or as noted herein).
2. The installation of all education technology cabling, regardless of type and separation requirements, from the head end room to various zones throughout the facility will use common pathway routes.
3. Inaccessible ceiling areas, such as lock-in ceiling tiles, drywall, or plaster, will not be used as distribution pathways. Should the contractor find inaccessible ceiling areas as the only available pathway, the contractor will notify the Architect immediately for direction prior to proceeding with the cable installation.
4. Accessible ceiling areas must have adequate and suitable space available for the distribution layout (minimum of three inches clear vertical space between ceiling tiles and distribution wiring and pathway).
5. The design shall provide a suitable means and method for supporting cables and wires from the head end room (and/or telecommunications closet) to the area being served. The cable will not be laid directly on the ceiling tiles or rail.
6. Cable support will be provided through the use of open-top cable supports located on 48-60 inch centers. Where large quantities of cables (50-75) are bunched together in the ceiling at a congested area, the contractor will use multiple open-top cable supports or a special support designed to carry the additional weight.

#### I. WIRING HARNESESSES

1. All wires and cables used in assembling custom panels and equipment racks shall be formed into harnesses, tied with Velcro tie wraps and supported in accordance with accepted engineering practice. T&B "Ty-raps" are not acceptable.
2. Harnessed cables shall be combed straight. Each cable that breaks out from a harness for termination shall be provided with an ample service loop. Cables shall be jacketed in black Polyethylene Terephthalate jacket.
3. Harnessed cables shall be formed in either a vertical or horizontal relationship to equipment, controls, components, or terminations.

### 3.07 GROUNDING

## A. GROUNDING PROCEDURE

1. The system wiring will conform to the following procedures:

ITEM	PROCEDURE
Equipment AC Ground Pins	Connect to AC ground.
Equipment Chassis	Connect to AC ground and/or rack frames
Rack Frames	Connect to AC ground. Use insulated bushings for all conduit connections.
Shielded Cable Between AC powered equipment:	Connect to ground at one end only.
Unbalanced Equipment	Float chassis from rack.
Conduit/Back Boxes	Isolate system wiring, including AC power, from all conduits and permanent back boxes.
AC Ground	Green wire (grounding conductor) system shall be isolated from all other facility grounds. Connects at one point to earth.

## B. METALLIC CONDUIT & ENCLOSURES

- 1) All metallic conduit, boxes, and enclosures shall be permanently and effectively grounded in accordance with the National Electrical Code. Metallic enclosures containing active equipment shall be grounded with due regard for minimization of electrical noise.

## 3.08 EQUIPMENT

### A. GENERAL

1. The equipment racks shall 4- Post units, be vented and considered as custom assemblies and shall be assembled, wired, and tested in a properly equipped shop maintained by the contractor. Assembly of racks on site will not be permitted.

### B. INSTALLATION

1. Run all low voltage lines and line level circuits (up to +30 dBm) in such a way as to maintain interference free circuits using conduits or other pathways dedicated to these purposes. Use electrical ducts within racks.
2. All lines in conduits must be insulated and shielded from each other and from the conduit the entire length and must not be spliced. Ground all line shields at the amplifier end of the respective circuits only. Use "wedge on" connectors or heat-shrink tubing to insulate the other end.
3. Ground all audio and video grounds effectively at one earth connection. Water pipes do not suffice as grounds. Use earth ground or approved equal. Use rosin core solder or standard mechanical connections and terminal strips for all joints and terminations.
4. The installation of all work must be in accordance with commonly accepted industry standards and practice. A qualified the Engineer shall exercise engineering supervision over the entire installation and inspect the installation at least twice prior to Acceptance Testing. It is the responsibility of the Contractor to coordinate and cooperate with other trades in order to achieve well-coordinated progress and satisfactory results. The Contractor must watch for

conflicts with work of other contractors on the job and execute moderate moves or changes as are necessary to accommodate other equipment or preserve symmetry and pleasing appearance. The Contractor is responsible to notify the Government as soon as possible initially by phone and then in writing of any issues throughout this contract duration.

5. All cable and wire ends shall be clearly tagged with destination and function markings in accordance with the wiring diagram.
6. Racks shall have power on one side and low voltage on the other side and shall be harnessed for clean appearance.
7. On all XLR connectors: Pin one is common/ground, pin two is high, and pin three is low.

#### C. EQUIPMENT LOCATION

1. Placement of equipment in equipment racks is for maximum operator convenience. Verify any changes in placement prior to assembly with the COTR. All system components and related wiring will be located with due regard for the minimization of induced electromagnetic and electrostatic noise, for the minimization of wiring length, proper ventilation, and to provide reasonable safety and convenience for the operator. Fans shall be provided if required for proper ventilation. All cabling to the racks shall be ceiling access and within enclosures extending from the racks into the ceiling area.

#### D. RACK INSTALLATION

1. Racks shall be installed plumb and square without twists in the frames or variations in level between adjacent racks.
2. Adequate ventilation and access shall be provided at all rack and equipment locations.

#### E. IDENTIFICATION

1. All terminal blocks, rack mounted equipment, and active slots of card frame systems shall be clearly and logically labeled in a manner acceptable to the COTR as to their function, circuit, or system as appropriate. Labeling on manufactured equipment shall be engraved plastic laminate with white lettering on black background or dark background. Handwritten identification is not permitted. The contractor may substitute metallized polyester permanent identification labels with black printing on silver, white, or another light color background for the phenolic labels above.

#### F. ELECTRICAL POWER

1. Each contractor responsible for the installation of a rack, cabinet or device connection is responsible to extend the electrical power located near or above the unit into the rack or cabinet. Electrical work must be performed by the Project electrician, approved by the COTR, and be in accordance to NEC.

### **3.09 TEST METHODOLOGY**

#### A. TEST DOCUMENTATION

1. Upon substantial completion of the provided equipment and interfacing of the Government supplied equipment, test operation and port for the functional requirements. Document, on a

contractor generated form; the compliance of every device and port and the testing individual will initial the results of each location. Submit a written report detailing the results of initial adjustments and verification tests including all relevant drawings, charts, and photographs. With the above report, submit written certification that the installation conforms to specifications, is complete, and is ready for inspection and testing by the Government.

#### B. COPPER CABLE TESTS (UTP)

1. The Contractor shall test and document each four (4) pair UTP data cable for the following conditions. A wire map test of the cable may be used to demonstrate conformance of the cable to the following parameters where applicable.
  - a. Proper polarity;
  - b. No reversals;
  - c. No transpositions;
  - d. Continuity;
  - e. No shorts
  - f. No AC voltage;
  - g. No DC voltage

#### C. COPPER CABLE TESTS (MULTI CONDUCTOR)

1. Proper numbering at each termination The Contractor shall test and document each cable for the following conditions. A wire map test of the cable may be used to demonstrate conformance of the cable to the following parameters where applicable.
  - a. Proper polarity;
  - b. No reversals;
  - c. No transpositions;
  - d. Continuity;
  - e. No shorts
  - f. No AC voltage;
  - g. No DC voltage
  - h. No opens;
  - i. Proper numbering at each termination

#### D. COAX CABLE TESTS

1. Proper numbering at each termination The Contractor shall test and document each cable for the following conditions. A wire map test of the cable may be used to demonstrate conformance of the cable to the following parameters where applicable.
  - h. Continuity;
  - i. No shorts
  - j. No AC voltage;
  - k. No DC voltage
  - l. No opens;
  - m. Proper numbering at each termination

### 3.10 VERIFICATION TEST REPORT

- A. Submit a signed written report detailing the results of initial adjustments and verification tests including all relevant drawings, charts, and photographs. This report will be completed and submitted for review at least five (5) days prior to acceptance testing.

### 3.11 ACCEPTANCE TESTING

- A. The Acceptance Testing and provision of testing equipment will be the responsibility of and performed by the Contractor in the presence of the COTR. Coordinate this period so that free access, work lighting and, electrical power is available on the site. Acceptance Tests may include speech intelligibility surveys and subjective evaluations by observers viewing and listening at various positions under various operating conditions, using video, speech, music, and live or recorded effects material. Acceptance tests shall include viewing of monitor images for sharpness, contrast, brightness, and color.
  
- B. Should the contractor schedule an Acceptance Test and the system or components are not ready for or fail Acceptance Testing, the contractor will pay for all subsequent trips and man-hours required for the COTR to properly document specification conformance by the contractor. The CO will have the right to reduce pay requests or final application of payment to the contractor in an amount equal to the travel costs and man-hours expended by the Consultant and charged to the contractor. The CO would then pay the Consultant from the funds withheld from the contractor.
  
- C. Upon witness of the Acceptance Testing and the determination, in the COTR's opinion, that the Contractor has falsified the Verification Test Reports, the CO has the right to hire an Independent Testing Agency to provide outside verification of the results. Falsification of the test results is defined as cables shown as testing correctly in the Verification Report that fail during the Acceptance Testing. (The Contractor has the right to hire an Independent Testing Agency approved by the CO and COTR directly.) Furthermore, the CO will have the right to reduce pay requests or final application of payment to the Contractor in an amount equal to the travel costs and man-hours expended by the Independent Testing Agency and Consultant and charged to the contractor. The CO would then pay the Independent Testing Agency and Consultant from the funds withheld from the contractor.

### 3.12 SYSTEM DOCUMENTATION

- A. Prior to substantial completion a preliminary submission includes:
  - 1. Service and Warrantee contact number, contact procedures.
  - 2. Service department employees and contractors to have security clearance
  - 3. A single line drawing of the installation (Provide one printed/ three on CD-ROM.)
  - 4. Verification and Acceptance Test Reports. (one printed/ three on CD-ROM)
  
- B. Upon completion of punch list items and prior to final acceptance submission includes:
  - 1. Service and Warrantee contact number, contact procedures.
  - 2. Service department employees and contractors to have security clearance
  - 3. All manufacturers' manuals for the equipment (Provide one printed/ three on CD-ROM).
  - 4. As-built project drawings. Provide (one printed/ three on CD-ROM)

\*\*\*\*\*END\*\*\*\*\*

GENERAL NOTES - ELECTRONIC SYSTEMS SCOPE OF WORK

1. ALL DIMENSIONS AND DETAILS OF WORK SHALL BE FIELD VERIFIED BY CONTRACTOR. ANY DISCREPANCIES SHALL BE BROUGHT TO THE ATTENTION OF THE GOVERNMENT BEFORE ANY RELATED WORK IS PERFORMED.
2. MINIMUM STANDARDS FOR ALL WORK SHALL BE LATEST REVISION OF THE NATIONAL ELECTRIC CODE (NEC). WHEREVER AND WHENEVER OSHA, FEDERAL, STATE AND LOCAL LAWS, REGULATIONS AND CRITERIA REQUIRE HIGHER STANDARDS, FOLLOW THE MOST STRINGENT.
3. UNLESS OTHERWISE INDICATED, ALL WIRING DEVICES SHALL BE INSTALLED FLUSH IN FLOOR, WALL OR CEILING. ELECTRICAL BOX LOCATIONS ARE APPROXIMATE UNLESS DIMENSIONED; COORDINATE LOCATION OF EQUIPMENT SERVED, EXISTING CONDITIONS AND VERIFY WITH THE GOVERNMENT AND THE TENANT IN FIELD FOR EXACT LOCATIONS.
4. CHECK WITH OTHER TRADES ON SCOPE OF THEIR WORK AND COORDINATE ON ALL LOCATIONS OF VARIOUS EQUIPMENT AND OTHER RELATED ITEMS. RELOCATION OF MATERIAL OR EQUIPMENT NECESSITATED BY FAILURE OF CONTRACTOR TO COORDINATE WORK SHALL BE AT NO COST TO GOVERNMENT OR THE THE TENANT.
5. ALTERATIONS & RENOVATIONS OF THE EXISTING BUILDING ARE SUCH THAT NOT EVERY FACET OF THE WORK CAN BE DESCRIBED, OR GRAPHICALLY ILLUSTRATED HEREIN. THE CONTRACTOR SHALL REVIEW THE ENTIRE SCOPE OF WORK AND PERSONALLY SURVEY THE EXISTING STRUCTURE TO FAMILIARIZE HIMSELF OF ALL THE REQUIREMENTS NECESSARY TO COMPLETE THE WORK. FAILURE TO COMPLY MAY RESULT IN ADDITIONAL EXPENSE TO THE CONTRACTOR FOR WHICH THE GOVERNMENT, TENANT NOR DESIGNER SHALL BE RESPONSIBLE.
6. PROVIDE FIRE STOPPING, INSULATION AT ALL RATED WALL, FLOOR AND CEILING PENETRATIONS. REFER TO ARCHITECTURAL PLANS OR VERIFY WITH GOVERNMENT FOR RATED LOCATIONS.
7. SPECIFIC MANUFACTURER AND MODEL ARE NOTED TO PROVIDE MINIMUM SPECIFICATIONS. SUBSTITUTIONS, ALTERNATE MANUFACTURER AND MODEL ARE ACCEPTABLE UPON WRITTEN APPROVAL BY GOVERNMENT, COURT AND DESIGNER.
8. SEE SCHEDULE B, CSI FORMAT SPECIFICATIONS FOR COMPLETE SCOPE OF WORK.
9. PROVIDE, INSTALL, TERMINATE AND TEST ALL CABLING, PLATES, AND PLATE MOUNTING ACCESSORIES INCLUDING CATEGORY 6 UTP TYPE CABLE. HOMERUN ALL CABLES FROM COURTROOM TO ES RACK LOCATION.
10. THE COURTROOM LAYOUT NEEDS TO BE FIELD COORDINATED. THE LAYOUT WAS CREATED BY FIELD MEASUREMENTS. ALL INFORMATION SHOWN IS FOR REFERENCE ONLY AND MAY NOT BE CURRENTLY LOCATED OR POSITIONED.
11. EXACT LAYOUT AND FIELD CONDITIONS MUST BE VERIFIED ON SITE.
12. REFER TO AV SPECIFICATIONS FOR LIST OF OFE EQUIPMENT.
13. ALL AV EQUIPMENT EXCEPT FOR OFE EQUIPMENT WILL BE SUPPLIED AND INSTALLED BY AV CONTRACTOR.
14. ALL AUDIO CABLES ARE EXISTING. ALL EXISTING CABLING SHALL BE TESTED AND VERIFIED TO BE IN PROPER WORKING CONDITION. ALL AV PATES ARE EXISTING.
15. ALL POWER RECEPTACLES ARE EXISTING.
16. ALL INFRASTRUCTURE IS EXISTING (CONDUIT, POWER, FLOOR BOXES, AND PATHWAYS).
17. DEVICE ICONS ARE NOT SCALED. DEVICE WILL BE CENTERED WHERE THE SYMBOL IS LOCATED AT EACH FLOOR, CEILING AND WALL LOCATION.
18. ALL UNUSED AUDIO CABLE SHALL BE LABELED ON BOTH ENDS. ALL UNUSED AUDIO CABLES SHALL BE REMOVED FROM THE RACK AND LABELED, COILED, AND NEATLY/ PROFESSIONALLY PLACED IN REAR OF RACK ROOM FOR FUTURE USE.

(FOR INFORMATION ONLY)

SCALE: -	PROJECT TITLE:	DRAWING TITLE:	NUMBER:
DRAWN BY: AD	AKRON, OH TYPICAL COURTROOM 18-PS4-111 FINAL ES DESIGN	GENERAL NOTES	0.1
DATE: 2018.07.30			
REV. DATE: -			

LINE DIAGRAM LEGENDS

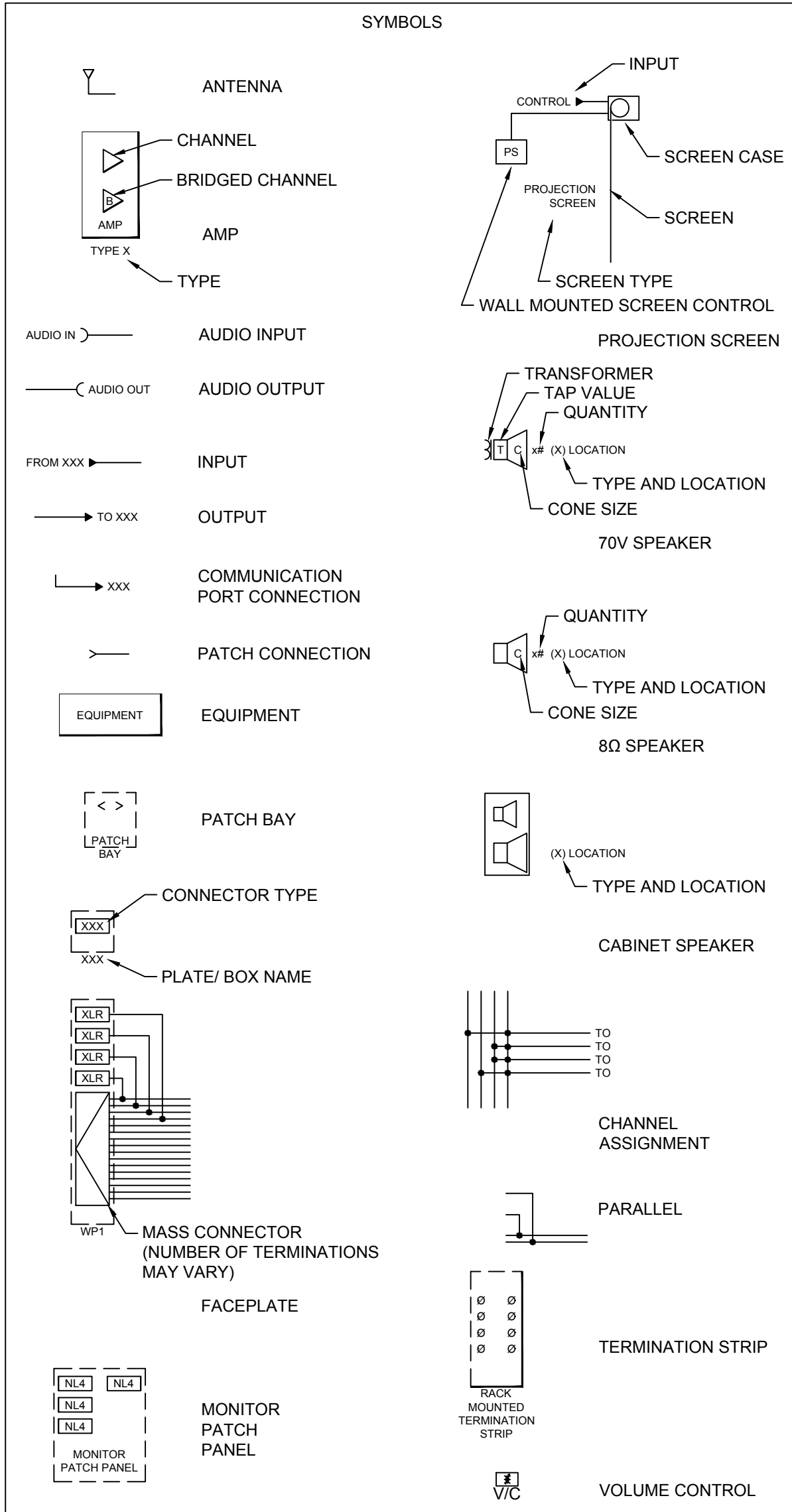

CONNECTION TYPES	
SYMBOL	CONNECTOR
1/4	TRS PHONE
1/8	3.5MM TRS MINI PHONE
BNC	BAYONET NEILL-CONCELMAN
DIN	DEUTSCHES INSTITUT FÜR NORMUNG
DP	DISPLAY PORT
DVID	DVI-DIGITAL DUAL LINK
DVII	DVI-INTEGRATED DUAL LINK
F	COAX F
HD15	VGA 15-PIN
HD9	RS232 9-PIN
HDMI	HDMI
LC	FIBER OPTIC LC
LGT	LIGHTNING
MASS	MASS CONNECTOR
MXLR	MINI XLR MALE
NL4	NEUTRIK NL4
NL8	NEUTRIK NL8
PHX	PHOENIX
RCA	PHONO
RJ11	PHONE CONNECTOR
RJ45	CATEGORY CABLE
SC	FIBER OPTIC SC
SJ45	SHIELDED RJ45
ST	FIBER OPTIC ST
SVID	S-VIDEO MINI DIN
USBA	UNIVERSAL SERIAL BUS - TYPE A
USBB	UNIVERSAL SERIAL BUS - TYPE B
USBM	UNIVERSAL SERIAL BUS - TYPE B MINI
XLR	XLR FEMALE
XLR4	XLR 4-PIN FEMALE
XLR5	XLR 5-PIN FEMALE
XLRM	XLR MALE
XLRC	COMBO XLR 1/4" STEREO JACK

(FOR INFORMATION ONLY)

SCALE: -  
 DRAWN BY: AD  
 DATE: 2018.07.30  
 REV. DATE: -

PROJECT TITLE:  
 AKRON, OH  
 TYPICAL COURTROOM  
 18-PS4-111  
 FINAL ES DESIGN







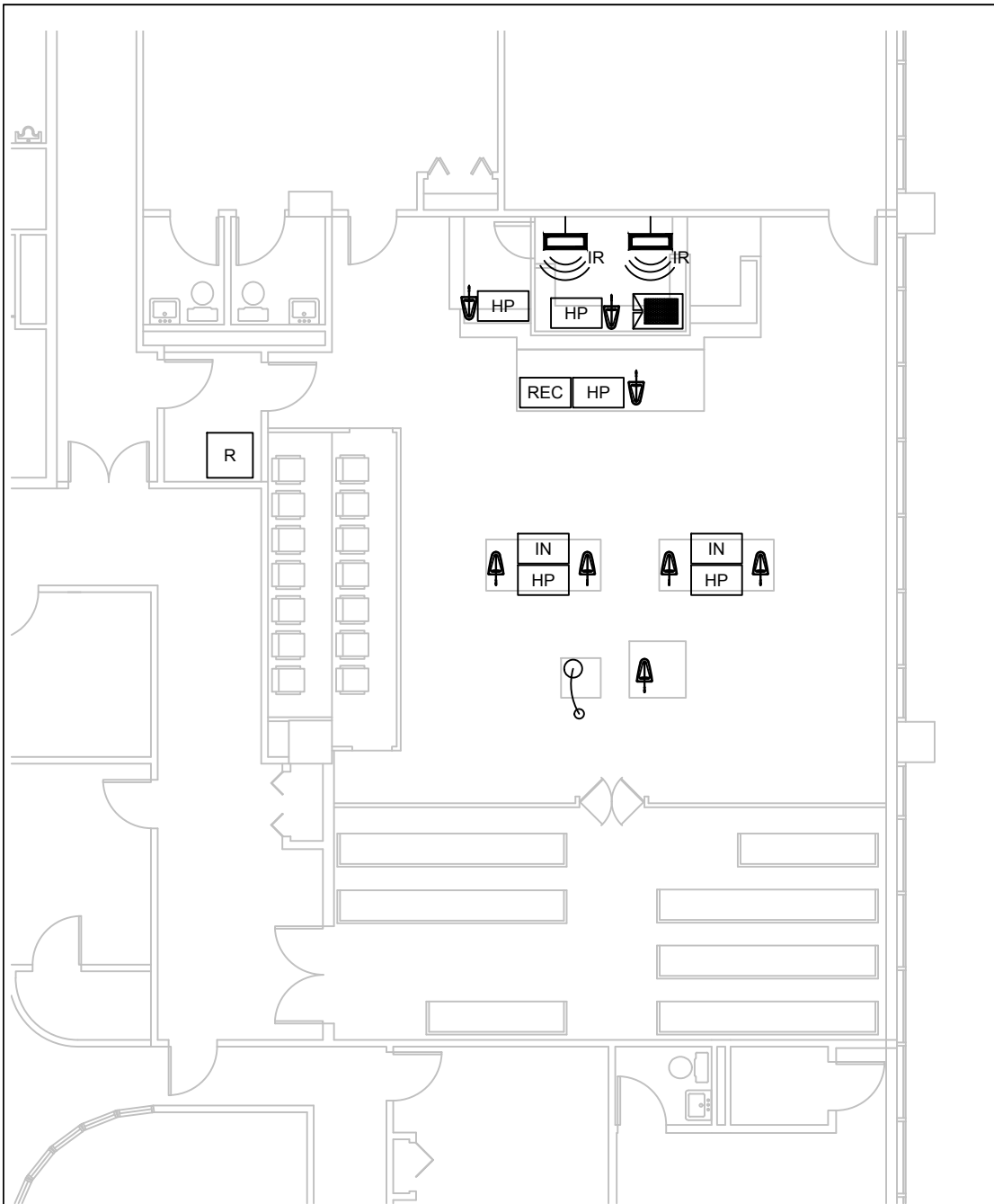



DRAWING TITLE:  
 TYPICAL DISTRICT COURTROOM  
 LINE DIAGRAMS LEGEND

NUMBER:  
**0.2**





AUDIO EQUIPMENT LEGEND

-  GOOSENECK MICROPHONE WITH BASE
-  GOOSENECK MICROPHONE (MILLWORK MOUNTED)
-  MICROPHONE ON STAND LOCATED
-  INFRARED EMITTER (MOUNT LOCATION SEE DWG 6.6)
-  DIGITAL RECORDING
-  DESK TOP SPEAKER
-  BENCH MICROPHONE
-  AUDIO VIDEO EQUIPMENT
-  COLUMN SPEAKER
-  HEADPHONE OUTPUT
-  AUX INPUT

GENERAL NOTES:

1. REFER TO AV SPECIFICATION FOR LIST OF OFE EQUIPMENT.
2. ALL AV EQUIPMENT EXCEPT FOR OFE WILL BE SUPPLIED AND INSTALLED BY THE AV CONTRACTOR.
3. ALL INFRASTRUCTURE IS EXISTING.
4. REFER TO PLATE DRAWINGS FOR PLATE DETAILS.
5. ALL CABLING IS EXISTING AND SHALL BE TESTED AND FIELD VERIFIED.
6. ALL PLATES AND CONNECTORS ARE EXISTING AND SHALL BE TESTED AND FIELD VERIFIED.

(FOR INFORMATION ONLY)

SCALE:	-
DRAWN BY:	AD
DATE:	2018.07.30
REV. DATE:	-

PROJECT TITLE:	AKRON, OH TYPICAL COURTROOM 18-PS4-111 FINAL ES DESIGN
----------------	-----------------------------------------------------------------

DRAWING TITLE:	TYPICAL DISTRICT COURTROOM AUDIO EQUIPMENT LAYOUT
----------------	---------------------------------------------------------

NUMBER:	1.1
---------	-----

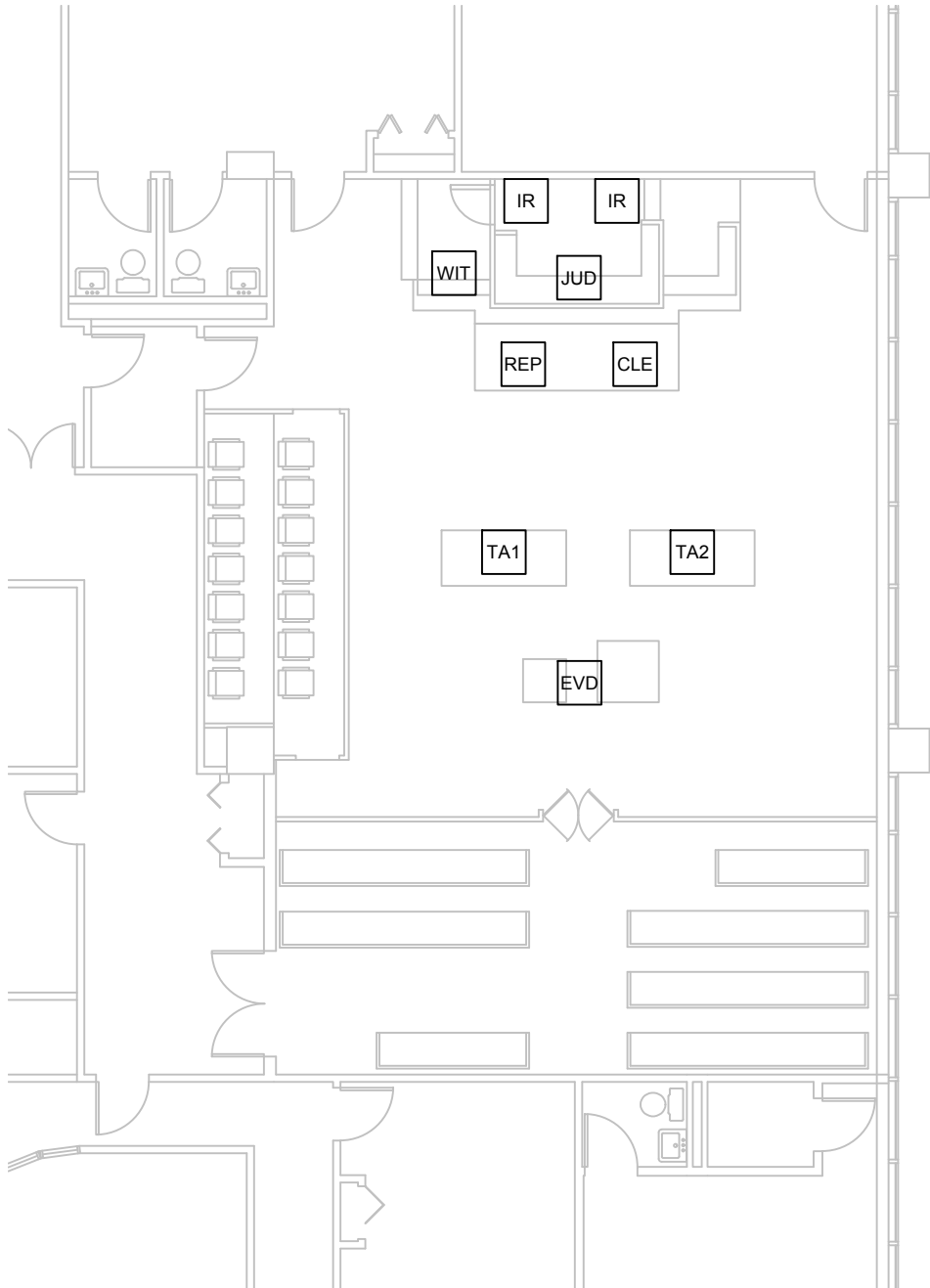

AV LEGEND

- IR ASSISTIVE LISTENING/  
TRANSMITTER EMITTER
- TA1 PROSECUTION FLOOR BOX  
AND TABLE LOCATION
- TA2 DEFENSE TABLE FLOOR BOX  
AND TABLE LOCATION
- EVD EVIDENCE CART/ LECTERN  
FLOOR BOX LOCATION
- CLE CLERK LOCATION
- REP REPORTER LOCATION
- JUD JUDGE LOCATION
- WIT WITNESS LOCATION

- GENERAL NOTES:
1. REFER TO AV SPECIFICATION FOR LIST OF OFE EQUIPMENT.
  2. ALL A/V EQUIPMENT EXCEPT FOR OFE WILL BE SUPPLIED AND INSTALLED BY THE AV CONTRACTOR.
  3. ALL INFRASTRUCTURE IS EXISTING.
  4. ALL CABLING IS EXISTING AND SHALL BE TESTED AND FIELD VERIFIED.
  5. ALL PLATES AND CONNECTORS ARE EXISTING AND SHALL BE TESTED AND FIELD VERIFIED.

(FOR INFORMATION ONLY)

SCALE:	-
DRAWN BY:	AD
DATE:	2018.07.30
REV. DATE:	-

PROJECT TITLE:

**AKRON, OH  
TYPICAL COURTROOM  
18-PS4-111  
FINAL ES DESIGN**

DRAWING TITLE:







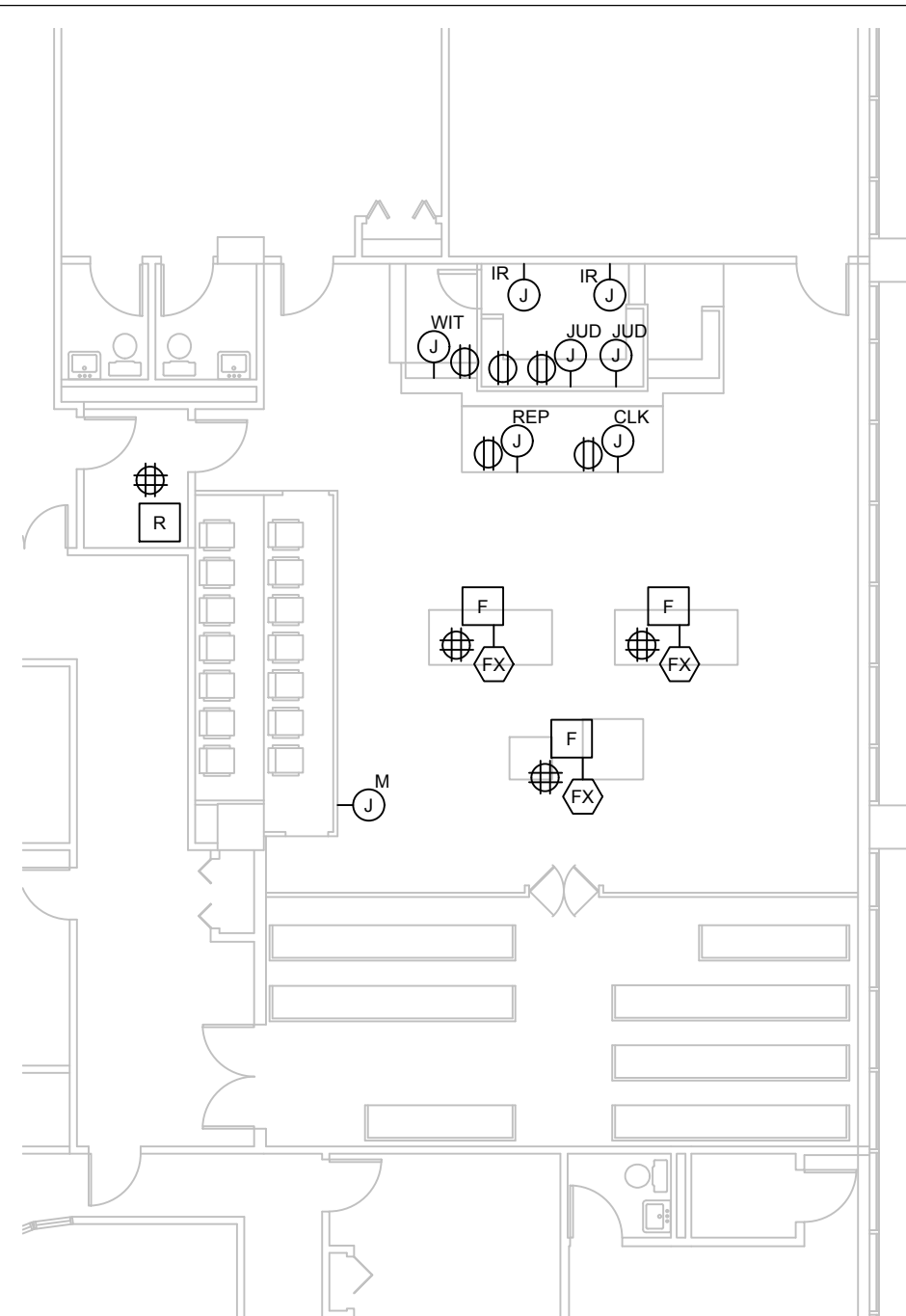





**TYPICAL DISTRICT  
COURTROOM AUDIO/  
CONTROL CABLING PLAN**

NUMBER:

**1.2**



AV INFRASTRUCTURE EQUIPMENT LEGEND

-  EXISTING FLOOR BOX VERIFY EXACT LOCATION IN FIELD
-  FLOOR BOX PLATE (REFERENCE TO PLATE DWG.)
-  EXISTING JUNCTION BOX. CABLES WILL RUN EXPOSED FROM JUNCTION BOX. EXISTING POWER RECEPTACLES. WILL REUSE EXISTING CONDUIT PATHWAYS TO EQUIPMENT RACK.
-  WIT
-  JUD
-  CLK
-  REP
-  IR
-  M
-  EXISTING POWER PROVIDED BY ELECTRICAL CONTRACTOR. DRAWING INDICATES LOCATION ONLY.
-  EXISTING QUAD POWER RECEPTACLE. POWER PROVIDED BY ELECTRICAL CONTRACTOR. DRAWING INDICATES LOCATION ONLY.
-  EQUIPMENT RACK

GENERAL NOTES:

1. REFER TO AV SPECIFICATION FOR LIST OF OFFE EQUIPMENT.
2. ALL A/V EQUIPMENT EXCEPT FOR OFFE WILL BE SUPPLIED AND INSTALLED BY THE A/V CONTRACTOR.
3. ALL INFRASTRUCTURE WILL BE EXISTING
4. REFER TO PLATE DRAWINGS FOR PLATE DETAILS.

(FOR INFORMATION ONLY)

SCALE:	-
DRAWN BY:	AD
DATE:	2018.07.30
REV. DATE:	-

PROJECT TITLE:	AKRON, OH TYPICAL COURTROOM 18-PS4-111 FINAL ES DESIGN
----------------	-----------------------------------------------------------------

DRAWING TITLE:	TYPICAL DISTRICT COURTROOM AV INFRASTRUCTURE LAYOUT (EXISTING)
----------------	----------------------------------------------------------------------

NUMBER:	1.3
---------	-----

LEGEND

(S) EXISTING RECESSED AV SYSTEM CEILING SPEAKER, LOCATION TO BE VERIFIED BY COURT.

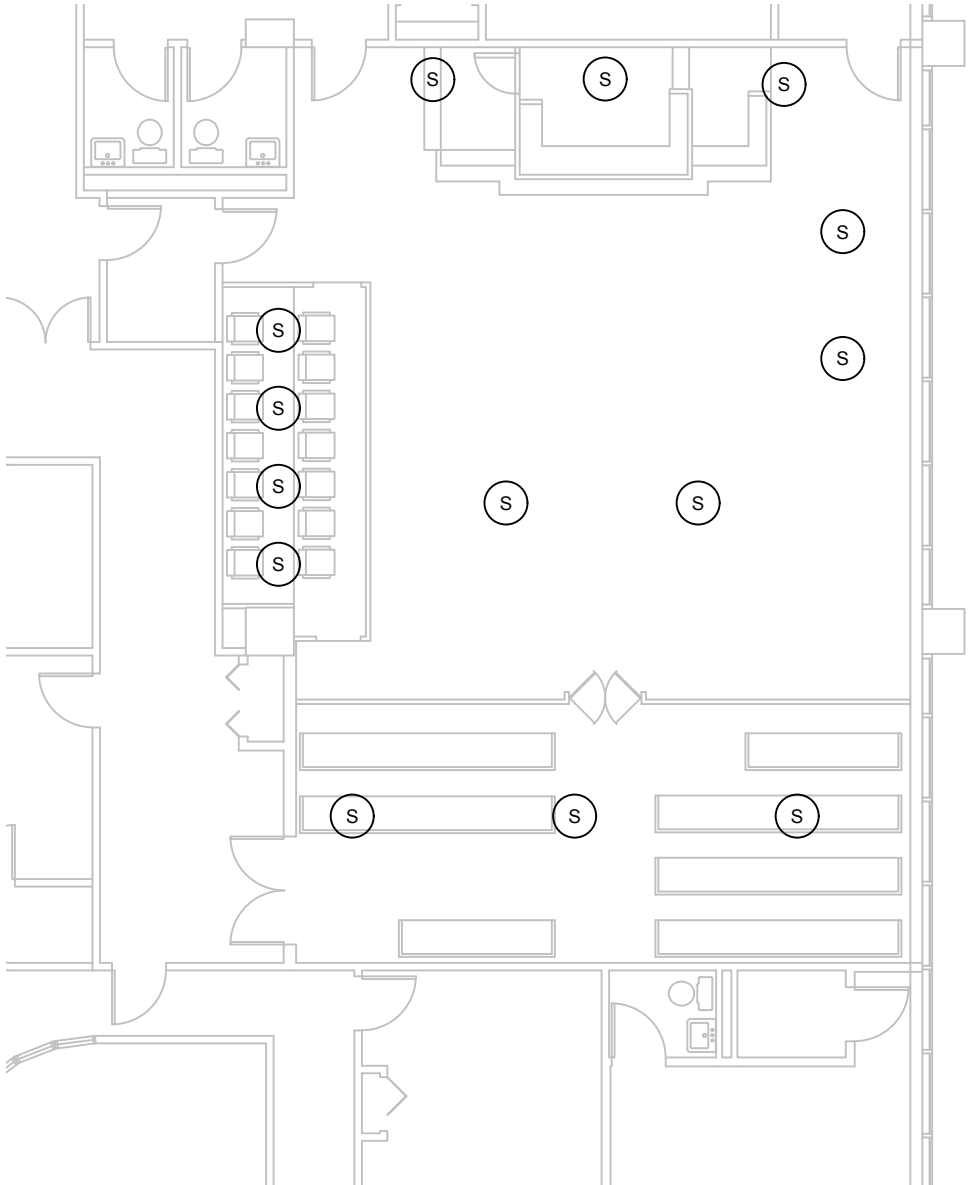

- GENERAL NOTES:
1. REFER TO AV SPECIFICATION FOR LIST OF OFE EQUIPMENT.
  2. ALL AV EQUIPMENT EXCEPT FOR OFE WILL BE SUPPLIED AND INSTALLED BY THE A/V CONTRACTOR.
  3. ALL INFRASTRUCTURE SHALL BE PROVIDED AND INSTALLED BY THE ELECTRICAL CONTRACTOR.
  4. ALL INFRASTRUCTURE IS EXISTING.
  5. ALL SPEAKERS ARE EXISTING AND SHALL BE TESTED AND FIELD VERIFIED.
  6. ALL CABLING IS EXISTING AND SHALL BE TESTED AND FIELD VERIFIED.

(FOR INFORMATION ONLY)

SCALE:	-
DRAWN BY:	AD
DATE:	2018.07.30
REV. DATE:	-

PROJECT TITLE:	<b>AKRON, OH</b> <b>TYPICAL COURTROOM</b> <b>18-PS4-111</b> <b>FINAL ES DESIGN</b>
----------------	---------------------------------------------------------------------------------------------

DRAWING TITLE:	<b>TYPICAL DISTRICT</b> <b>COURTROOM EXISTING</b> <b>CEILING SPEAKER LAYOUT</b>
----------------	---------------------------------------------------------------------------------------

NUMBER:	<b>1.4</b>
---------	------------

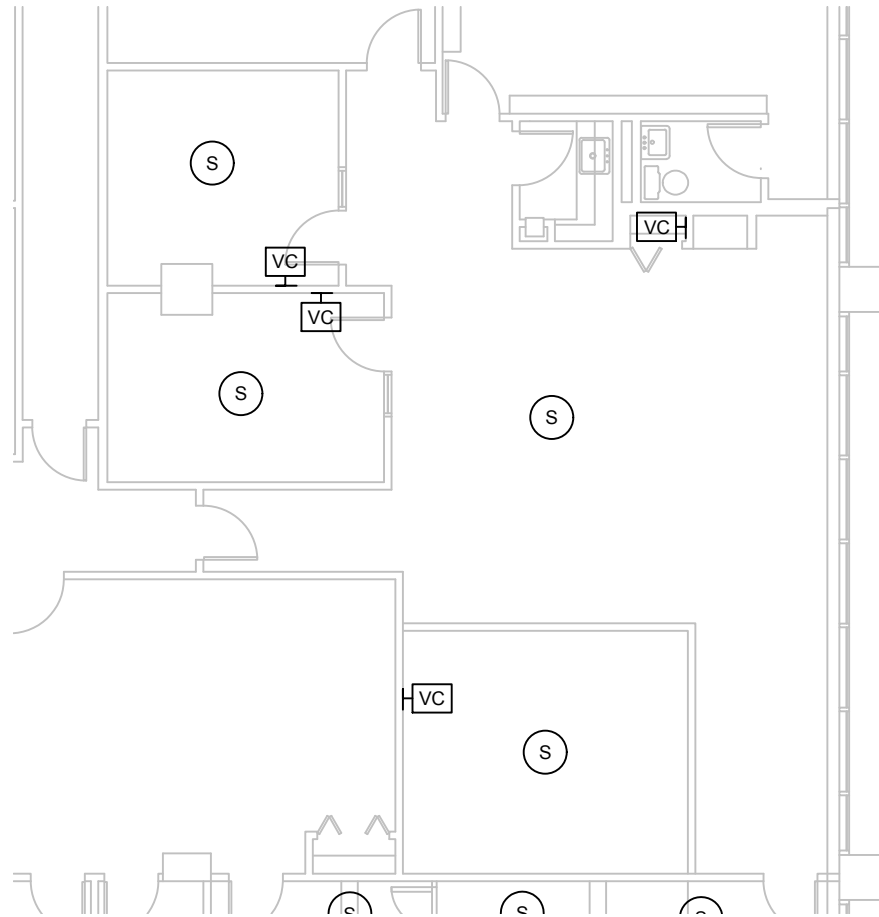

GENERAL NOTES:

1. REFER TO AV SPECIFICATION FOR LIST OF OFE EQUIPMENT.
2. ALL A/V EQUIPMENT EXCEPT FOR OFE WILL BE SUPPLIED AND INSTALLED BY THE AV CONTRACTOR.
3. ALL INFRASTRUCTURE SHALL BE PROVIDED AND INSTALLED BY THE ELECTRICAL CONTRACTOR.
4. ALL INFRASTRUCTURE IS EXISTING.
5. ALL SPEAKERS ARE EXISTING AND SHALL BE TESTED AND FIELD VERIFIED.
6. ALL CABLING IS EXISTING AND SHALL BE TESTED AND FIELD VERIFIED.

LEGEND



EXISTING RECESSED AV SYSTEM CEILING SPEAKER, LOCATION TO BE VERIFIED BY COURT.



EXISTING WALL MOUNTED VOLUME CONTROL, LOCATION TO BE VERIFIED BY COURT.  
EXISTING A DOUBLE GANG DEEP JUNCTION BOX WITH SINGLE GANG RING AT STANDARD SWITCH HEIGHT. EXISTING 1" CONDUIT TO ASSOCIATED AV RACK TYPICAL.

(FOR INFORMATION ONLY)

SCALE: -	PROJECT TITLE: AKRON, OH TYPICAL COURTROOM 18-PS4-111 FINAL ES DESIGN	DRAWING TITLE: TYPICAL CHAMBERS SPEAKER LAYOUT (EXISTING)	NUMBER: 1.5
DRAWN BY: AD			
DATE: 2018.07.30			
REV. DATE: -			

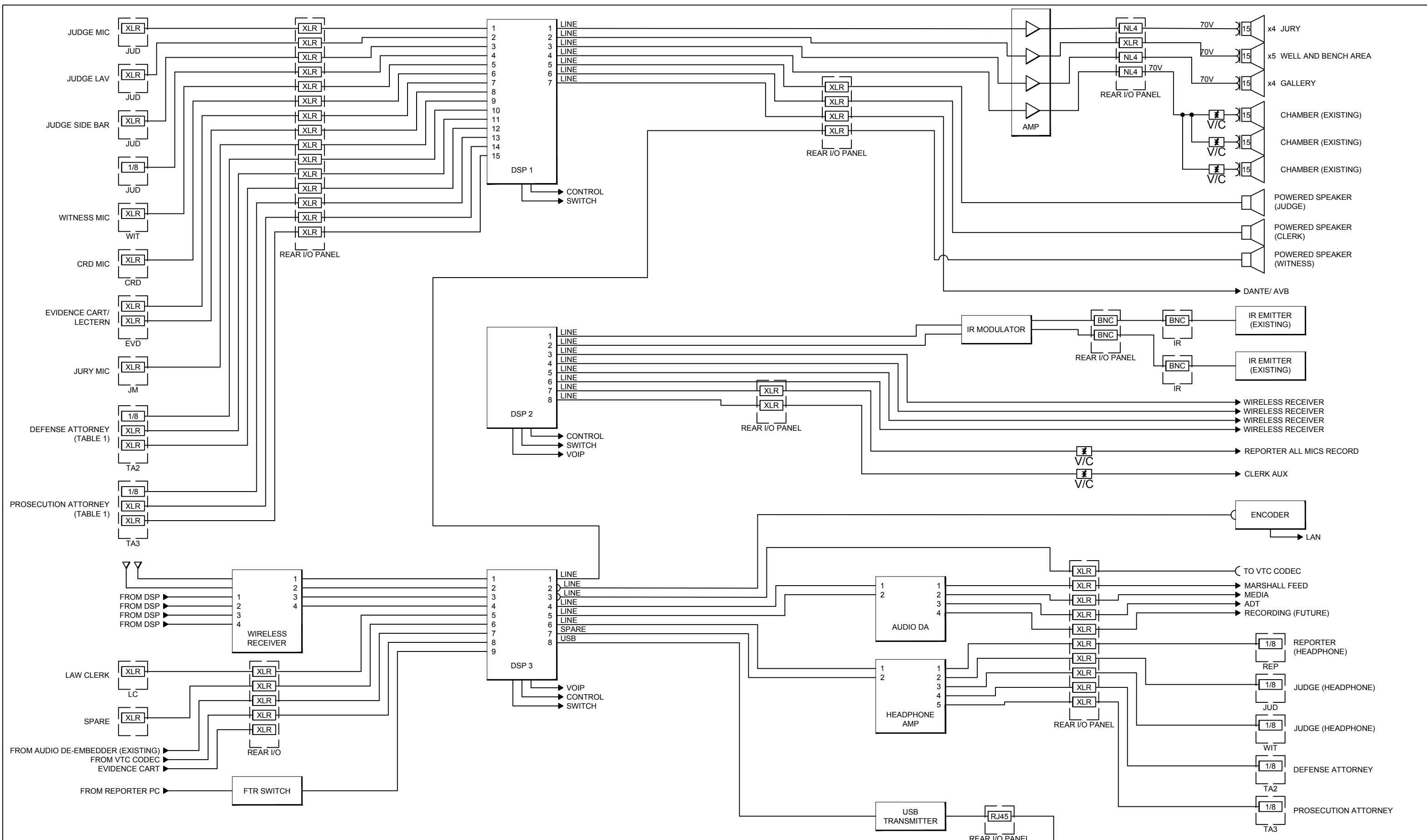

SCALE:	-
DRAWN BY:	AD
DATE:	2018.07.30
REV. DATE:	-

PROJECT TITLE:  
**AKRON, OH  
 TYPICAL COURTROOM  
 18-PS4-111  
 FINAL ES DESIGN**

DRAWING TITLE:  
**TYPICAL DISTRICT  
 AUDIO LINE DIAGRAM**

NUMBER:  
**4.1**

(FOR INFORMATION ONLY)

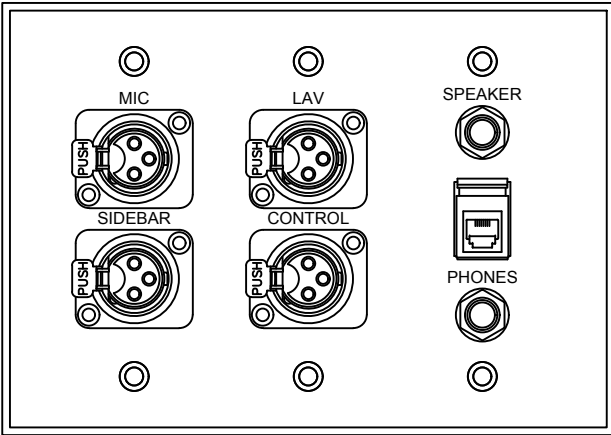

JUD

**JUDGE'S WALL PLATE**

QUANTITY: SEE DRAWINGS

SIZE: EXISTING

FINISH: EXISTING

NOTE: PLATE AND CONNECTORS ARE EXISTING.  
REMOVE SPEAKER AND PHONES CONNECTORS.  
ABANDON CABLES IN PLACE

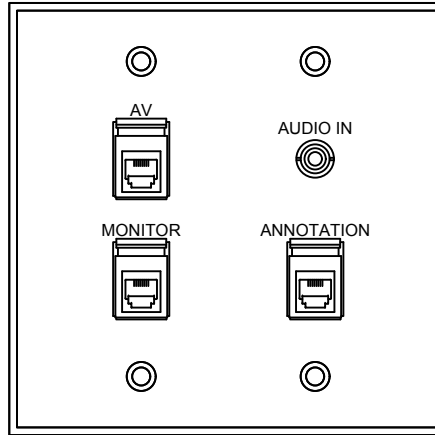

JUD

**JUDGE'S WALL PLATE**

QUANTITY: SEE DRAWINGS

SIZE: EXISTING

FINISH: EXISTING

NOTE: PLATE AND CONNECTORS ARE EXISTING.

**GENERAL NOTES:**

1. ALL PLATES ARE EXISTING, UNLESS OTHERWISE NOTED.

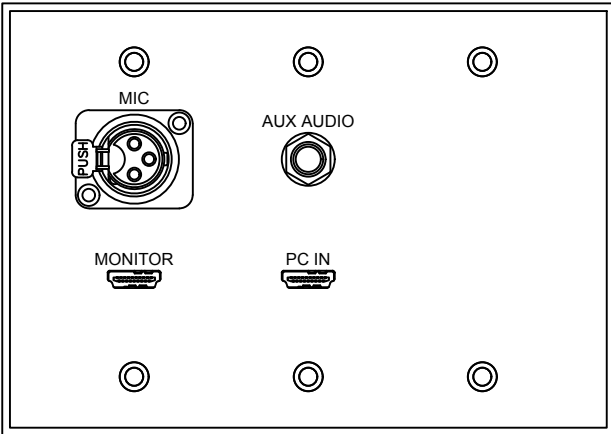

TA1

**ATTORNEY TABLE PLATES**

QUANTITY: SEE DRAWINGS

SIZE: EXISTING

FINISH: EXISTING

NOTE: PLATE AND CONNECTORS ARE EXISTING.  
HEAD PHONE JACK SHALL BE NEW.

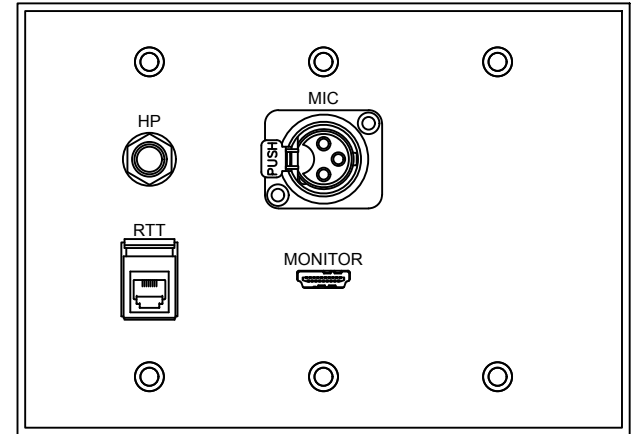
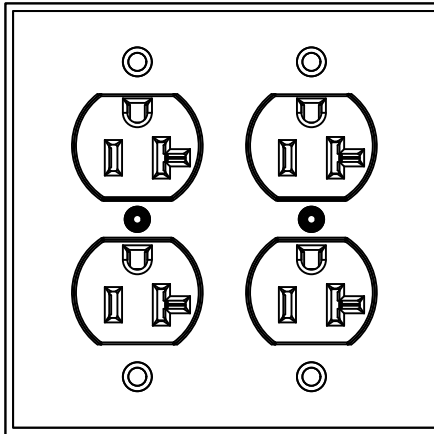

(FOR INFORMATION ONLY)

SCALE:	-
DRAWN BY:	AD
DATE:	2018.07.30
REV. DATE:	-

PROJECT TITLE:	AKRON, OH TYPICAL COURTROOM 18-PS4-111 FINAL ES DESIGN
----------------	-----------------------------------------------------------------

DRAWING TITLE:	TYPICAL DISTRICT PLATE DETAILS
----------------	-----------------------------------

NUMBER:	5.1
---------	-----

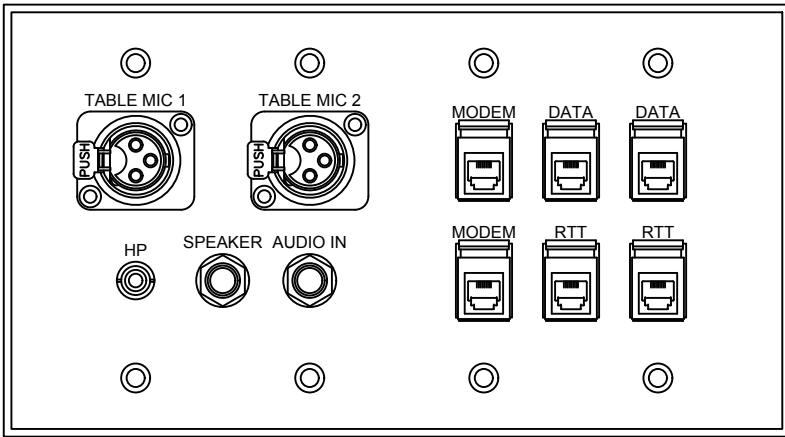

FA1 FA2

### ATTORNEY TABLE FLOOR BOX PLATES

QUANTITY: SEE DRAWINGS

SIZE: EXISTING

FINISH: EXISTING

NOTE: PLATE AND CONNECTORS ARE EXISTING.  
REMOVE SPEAKER ABANDON CABLES IN PLACE

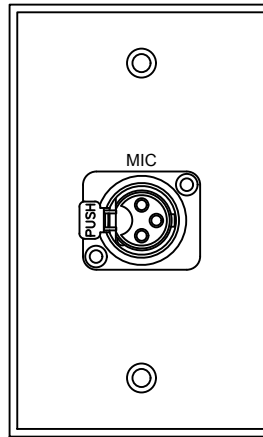

M

### JURY MIC PLATE

QUANTITY: SEE DRAWINGS

SIZE: EXISTING

FINISH: EXISTING

NOTE: PLATE AND CONNECTORS ARE EXISTING.

#### GENERAL NOTES:

1. ALL PLATES ARE EXISTING, UNLESS OTHERWISE NOTED.

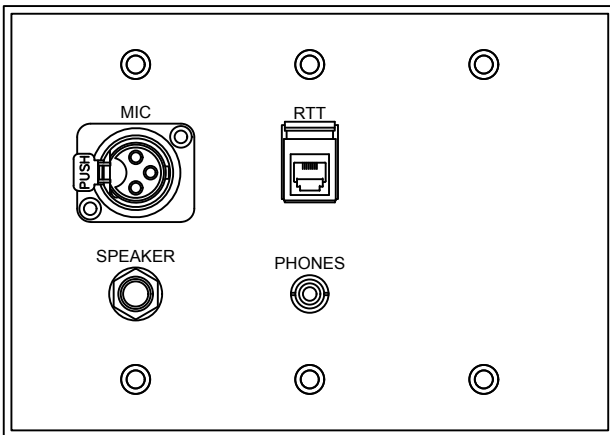

WIT

### WITNESS PLATE

QUANTITY: SEE DRAWINGS

SIZE: EXISTING

FINISH: EXISTING

NOTE: PLATE AND CONNECTORS ARE EXISTING.  
REMOVE SPEAKER CONNECTOR.  
ABANDON CABLES IN PLACE.

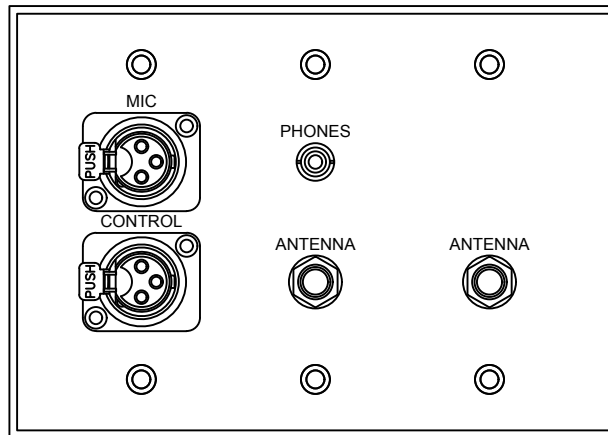

CLK

### CLERK WALL PLATE

QUANTITY: SEE DRAWINGS

SIZE: EXISTING

FINISH: EXISTING

NOTE: REMOVE ALL CONNECTORS EXCEPT  
ANTENNA CONNECTORS. ABANDON CABLES IN PLACE.

(FOR INFORMATION ONLY)

SCALE:	-
DRAWN BY:	AD
DATE:	2018.07.30
REV. DATE:	-

PROJECT TITLE:	AKRON, OH TYPICAL COURTROOM 18-PS4-111 FINAL ES DESIGN
----------------	-----------------------------------------------------------------

DRAWING TITLE:	TYPICAL DISTRICT PLATE DETAILS
----------------	-----------------------------------

NUMBER:	5.2
---------	-----



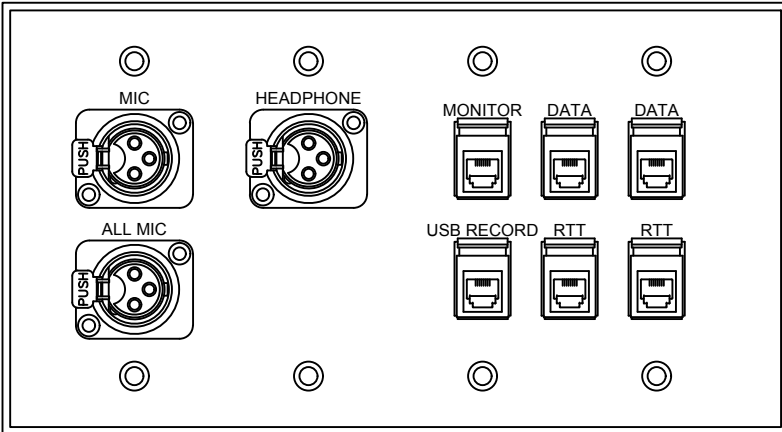

REP

### REPORTER WALL PLATE

QUANTITY: SEE DRAWINGS

SIZE: EXISTING

FINISH: EXISTING

NOTE: PLATE AND CONNECTORS ARE EXISTING.  
REMOVE ALL MIC XLR. ADD RJ45 FOR USB RECORDING

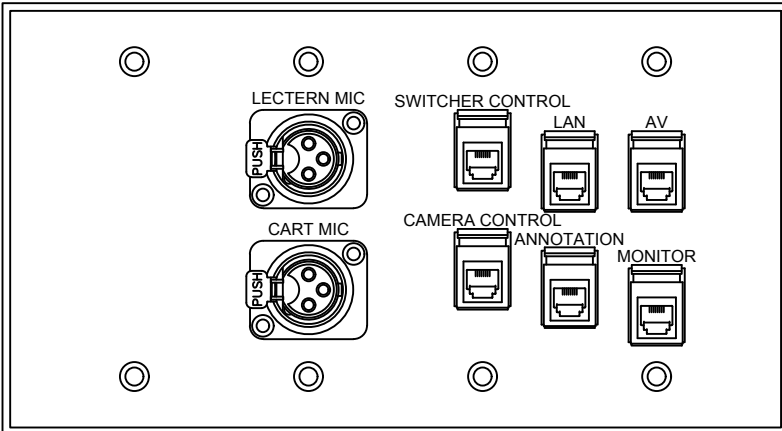

FL

### EVIDENCE CART FLOOR BOX PLATE

QUANTITY: SEE DRAWINGS

SIZE: EXISTING

FINISH: EXISTING

NOTE: PLATE AND CONNECTORS ARE EXISTING.

- GENERAL NOTES:  
1. ALL PLATES ARE EXISTING, UNLESS OTHERWISE NOTED.

(FOR INFORMATION ONLY)

SCALE:	-
DRAWN BY:	AD
DATE:	2018.07.30
REV. DATE:	-

PROJECT TITLE:	AKRON, OH TYPICAL COURTROOM 18-PS4-111 FINAL ES DESIGN
----------------	-----------------------------------------------------------------

DRAWING TITLE:	TYPICAL DISTRICT PLATE DETAILS
----------------	-----------------------------------

NUMBER:	5.3
---------	-----

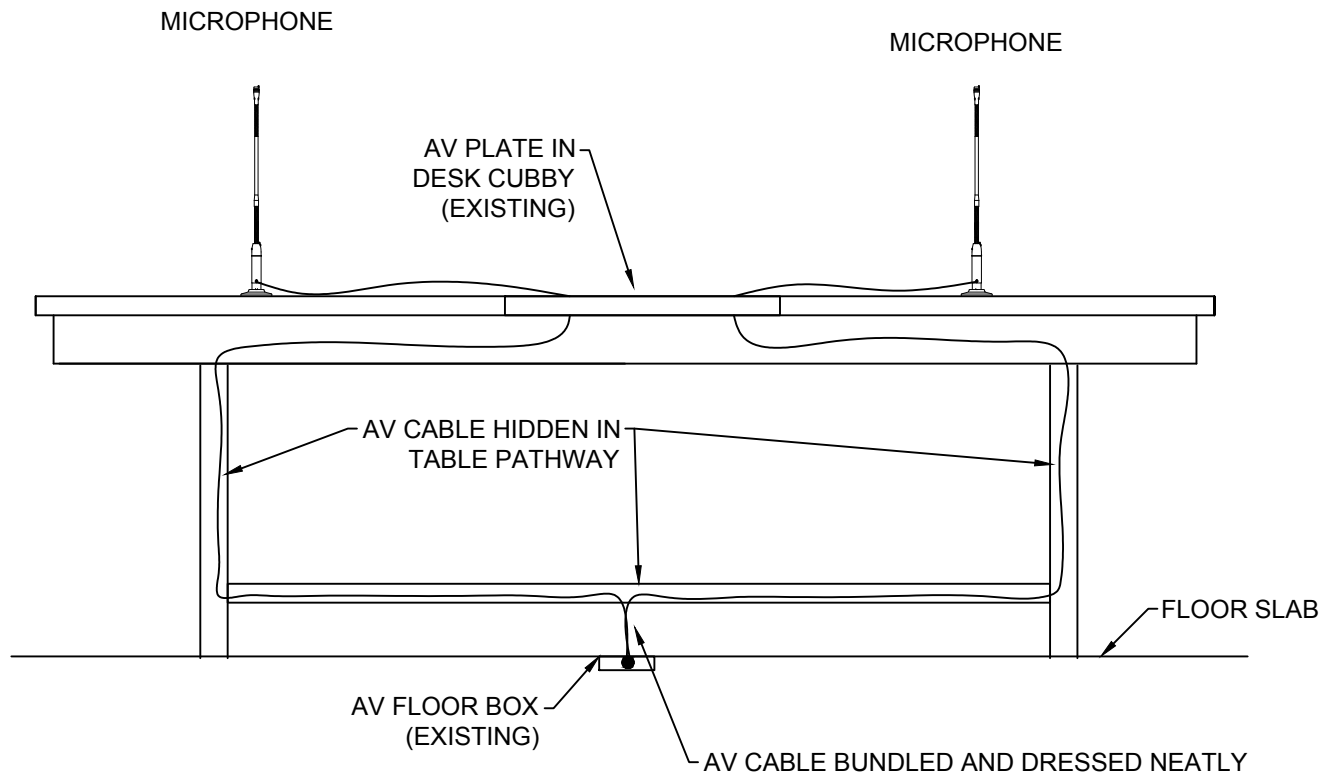

(FOR INFORMATION ONLY)

SCALE:	-
DRAWN BY:	AD
DATE:	2018.07.30
REV. DATE:	-

PROJECT TITLE:	AKRON, OH TYPICAL COURTROOM 18-PS4-111 FINAL ES DESIGN
----------------	-----------------------------------------------------------------

DRAWING TITLE:	ATTORNEY TABLE DEVICE LAYOUT
----------------	------------------------------

NUMBER:	6.1
---------	-----

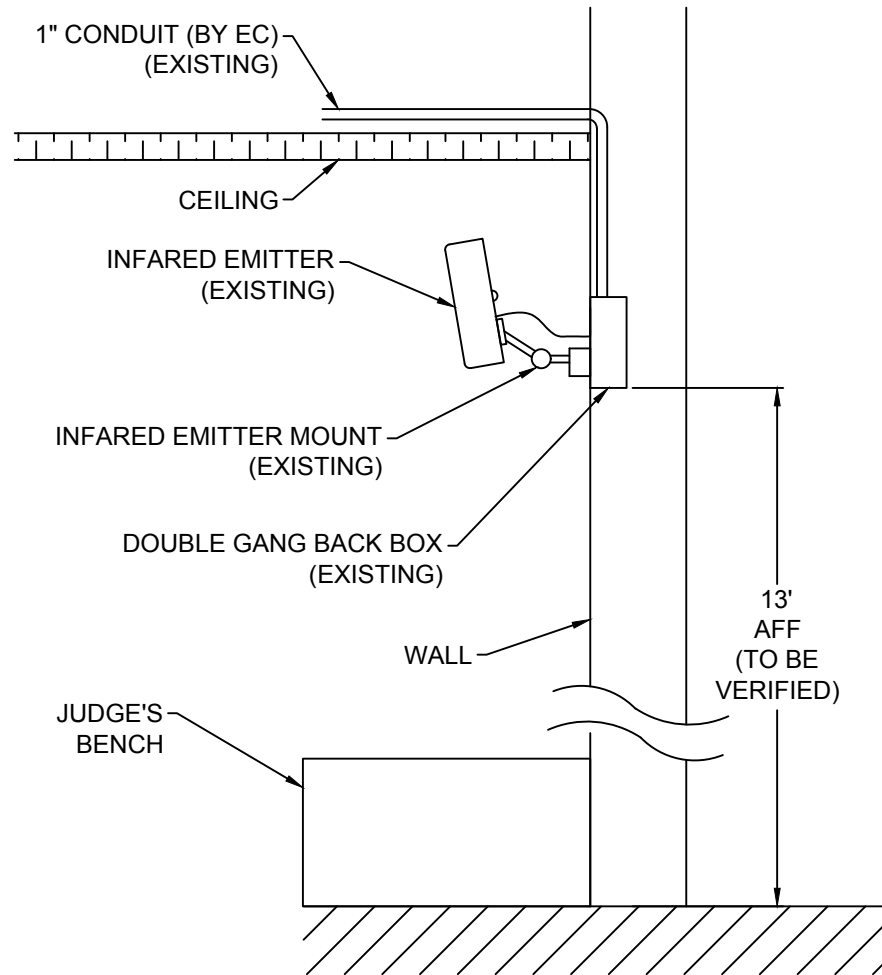

(FOR INFORMATION ONLY)

SCALE:	-
DRAWN BY:	AD
DATE:	2018.07.30
REV. DATE:	-

PROJECT TITLE:	AKRON, OH TYPICAL COURTROOM 18-PS4-111 FINAL ES DESIGN
----------------	-----------------------------------------------------------------

DRAWING TITLE:	INFARED EMITTER DETAIL
----------------	------------------------

NUMBER:	6.2
---------	-----

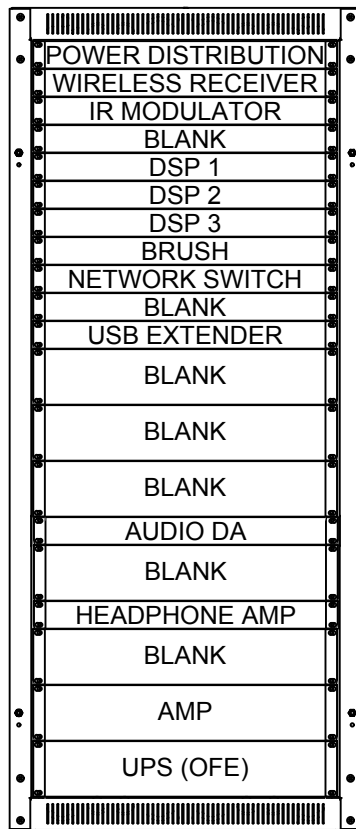

RACK

TOTAL AMPS: 15  
 TOTAL WATTS: 1650  
 TOTAL BTU: 5630  
 CIRCUITS: EXISTING

(FOR INFORMATION ONLY)

SCALE: -	PROJECT TITLE: AKRON, OH TYPICAL COURTROOM 18-PS4-111 FINAL ES DESIGN	DRAWING TITLE:	NUMBER:
DRAWN BY: AD		RACK ELEVATIONS	6.3
DATE: 2018.07.30			
REV. DATE: -			

# DATA SHEET

## TESIRAFORTÉ® AVB VT FIXED AUDIO DSP



The TesiraFORTÉ® AVB VT is a fixed audio DSP with 12 analog inputs and 8 analog outputs and includes Acoustic Echo Cancellation (AEC) technology on all 12 inputs. It includes up to 8 channels of configurable USB audio, a 2-channel VoIP interface, and a standard FXO telephone interface. USB audio allows TesiraFORTÉ to interface directly with USB audio hosts, as well as to take full advantage of today's most sophisticated conferencing solutions. TesiraFORTÉ AVB VT utilizes Audio Video Bridging (AVB) for digital audio networking, and can be used as standalone device or combined with other TesiraFORTÉ AVB devices and Tesira servers, expanders, endpoints, and controllers. TesiraFORTÉ AVB VT also provides extensive audio processing, including but not limited to: AEC technology, signal routing and mixing, equalization, filtering, dynamics, and delay, as well as control, monitoring, and diagnostic tools; all configured through the Tesira configuration software. TesiraFORTÉ AVB VT is best-suited for rooms that require high-quality audio solutions using VoIP, voice lift, mix-minus, and AEC, such as conference rooms or distance learning environments.

### BENEFITS

- Integrates VoIP, POTS, and USB audio in one product allowing integrators to choose the type of audio conferencing that works best for their installation
- AVB allows audio networking via IEEE open standards protocol
- Includes default configuration file allowing for plug-and-play usage
- Highly scalable and cost-effective solution that can grow over time with the needs of the customer
- SpeechSense™ technology to enhance speech processing
- Integrates directly with soft codecs and other USB audio hosts

### FEATURES

- 128 x 128 channels of AVB
- 12 mic/line level inputs with AEC, 8 mic/line level outputs
- Gigabit Ethernet port
- Up to 8 channels of configurable USB audio
- RS-232 serial port
- 4-pin GPIO
- 2-line OLED display with capacitive-touch navigation
- Rack mountable (1RU)
- System configuration and control via Ethernet
- Internal universal power supply
- SIP VoIP interface via a RJ-45 connector
- Standard FXO telephone interface via RJ-11 connector
- Fully compatible with Tesira AVB servers, endpoints, expanders, and controllers
- Signal processing via intuitive software allows configuration and control for signal routing, mixing, equalization, filtering, delay and much more
- CE marked, UL listed, and RoHS compliant
- Covered by Biamp Systems' 5-year warranty

## ARCHITECTS & ENGINEERS SPECIFICATION

The fixed audio DSP shall be designed exclusively for use with Tesira® systems. The audio DSP shall support Audio Video Bridging (AVB) digital audio networking that shall allow up to 128 x 128 channels. The AVB networking connection shall be implemented on a RJ-45 connector. The audio DSP shall support Ethernet connection for programming and control on a RJ-45 connector. The audio DSP shall have internal DSP processing. The audio DSP shall include 4 channels of General Purpose Input and Output connection (GPIO) for sending or receiving logic signals. The programming of the GPIO ports shall be software configurable. The audio DSP shall include a RS-232 connection for control data transmission into or out of the audio DSP and such operation shall be software programmable. The audio DSP shall include a Universal Serial Bus (USB) connection on a standard USB-B type connector. The audio DSP shall be software configurable to stream up to 8 channels of digital USB Class 1 Audio transmission either into or out of the audio DSP or simultaneous input and output. The audio DSP shall provide 12 balanced input connections for receiving of microphone or line level analog audio signals on screw-down, removable connectors. The input connections shall include Acoustic Echo Cancellation (AEC) hardware and firmware, the parameters, routing and operation of which shall be software programmable. The audio DSP shall provide 8 balanced output channels for the transmission of microphone or line level analog audio signals on screw-down, removable connectors. Each individual channel shall have its own dedicated connection. The audio DSP shall integrate to Voice Over Internet Protocol (VoIP) systems on a RJ-45 connector for two lines of VoIP communication and shall support Session Initiation Protocol (SIP) v2.0 or later. The audio DSP shall integrate to standard telephony communications on a RJ-11 connector for a single line of telephone communication. The audio DSP shall provide front panel OLED identification of device power, status, alarm, and activity as well as system-wide alarm. The audio DSP shall be rack mountable (1RU) and feature software-configurable signal processing, including but not limited to: signal routing and mixing, equalization, filtering, dynamics, and delay, as well as control, monitoring, and diagnostic tools. The audio DSP shall control and proxy all Tesira expander-class devices and Tesira control devices. The audio DSP shall be CE marked, UL listed, and shall be compliant with the RoHS directive. Warranty shall be five years. The fixed audio DSP shall be TesiraFORTÉ AVB VT.

## TESIRAFORTÉ AVB VT SPECIFICATIONS

<b>Frequency Response:</b> 20Hz to 20kHz, +4dBu output:	+0.25 dB/-0.5 dB	<b>Phantom Power:</b>	+48VDC (7mA/input)
<b>THD+N (22Hz to 22kHz):</b> 0dB gain, +4dBu input:	< 0.006%	<b>Crosstalk, channel to channel, 1 kHz:</b> 0dB gain, +4dBu input:	< -85dB
54dB gain, -50dBu input:	< 0.040%	54dB gain, -50dBu input:	< -75dB
<b>EIN</b> (no weighting, 22Hz to 22kHz):	< -125dBu	<b>Sampling Rate:</b>	48kHz
<b>Dynamic Range</b> (in presence of signal) 22Hz to 22kHz, 0dB gain:	> 108dB	<b>A/D - D/A Converters:</b>	24-bit
<b>Input Impedance</b> (balanced):	8kΩ	<b>Power Consumption:</b> 100-240VAC 50/60Hz:	< 35W
<b>Output Impedance</b> (balanced):	207Ω	<b>USB:</b> Bit Depth:	16- or 24-bit
<b>Maximum Input:</b>	+24dBu	Number of Channels:	up to 8
<b>Maximum Output</b> (selectable):	+24dBu, +18dBu, +12dBu, +6dBu, 0dBu, -31dBu	Sample Rate:	48kHz
<b>Input Gain Range</b> (6dB steps):	0-66dB	<b>Compliance:</b>	FCC Part 15B (USA) FCC Part 68 (USA) Industry Canada CS-03 (Canada) CE marked (Europe) UL und C-UL listed (USA and Canada) RCM (Australia) RoHS Directive (Europe)
<b>Overall Dimensions:</b> Height:	1.75 inches (44 mm)		
Width:	19.0 inches (483 mm)		
Depth:	10.5 inches (267 mm)		
Weight:	8 lbs (3.63 kg)		
<b>Environment:</b> Ambient Operating Temperature Range:	32-104° F (0-40° C)		
Humidity:	0-98%, non-condensing		
Altitude:	0-6,600 feet (0-2000 Meters) MSL		

## TESIRAFORTÉ AVB VT BACK PANEL

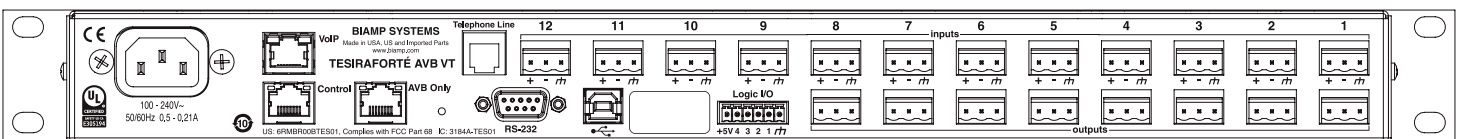

# OWNER'S MANUAL

*CONDITIONED POWER DISTRIBUTION  
SEQUENTIAL POWER UP / POWER DOWN*



PD11 SP



PD11 SS



PD11 P

PD11 VP

PD11 LP

PD11 LVP

PD11 LVSP

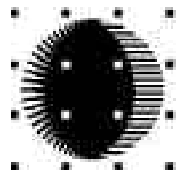

**ETA** SYSTEMS

*A Creative Light & Sound Company*

1532 Enterprise Parkway • Twinsburg, Ohio 44087

330-425-3388 • 800-321-6699 • Fax: 330-425-9700

<http://www.etasys.com> E-mail [eta@etasys.com](mailto:eta@etasys.com)

ETA's line of *Conditioned Power Distribution* units are designed to reduce damage to sensitive electronic equipment from sudden voltage spikes, damaging power surges, and EMI/RFI noise, which is inherent in utility power lines.

The PD11SP is a sequential four step/stage power up/down conditioned power distribution unit. It is designed to protect electronic equipment that requires a time-delayed start-up, particularly when high in-rush current can potentially damage audio, video, or computer equipment at power up.

PD11SP units are shipped with the ability to be linked or daisy chained. All linked units function as slaves; however, slaves can be set to specific time delays. Any number of units can be linked together with a distance of up to 1000 feet between each location (see Fig. 4).

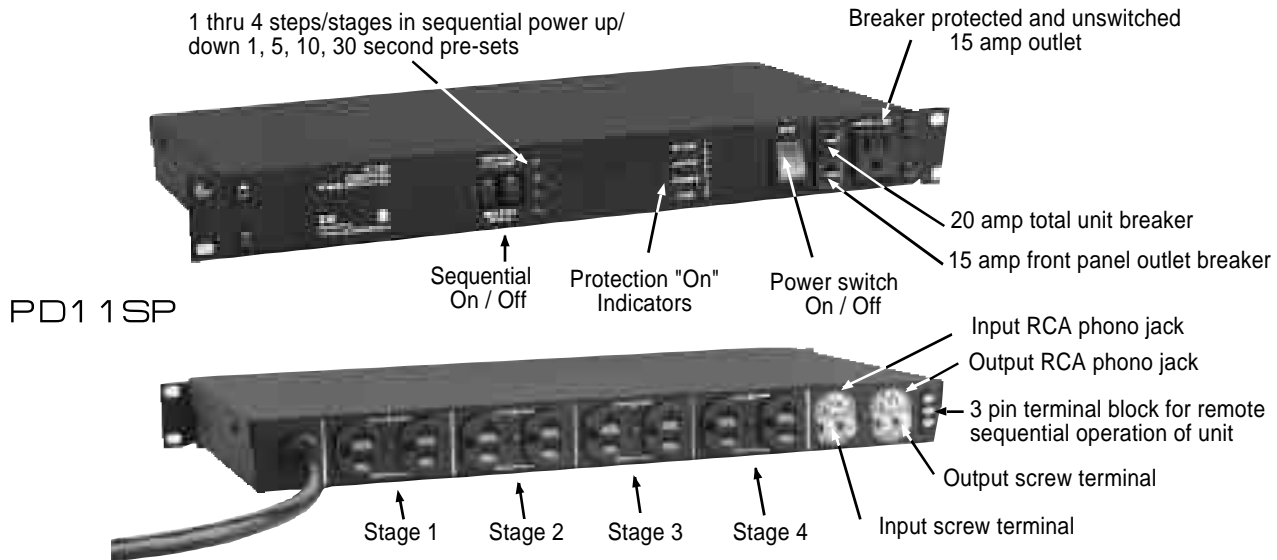

#### PD11SP Features:

- Microprocessor monitored sequential power distribution system
- Four power up/down steps or stages of distributed and conditioned power
- Four pre-set power up/down intervals of 1, 5, 10 or 30 seconds
- Optional manual settings for up to 240 seconds between intervals
- One dual 20 amp U-grounded outlet per stage
- Full 20 amps, 2400 watt capacity per unit
- 12-gauge, 3-prong, 10-foot, 20-amp power cord. Requires 20 amp circuit and receptacle outlet
- Protected "always on" 15 amp AC power outlet on the front panel
- Total unit 20 amp and 15 amp outlet circuit breakers located on front panel
- Three-stage spike and surge protection
- Two-stage EMI/RFI filtration
- Ground and AC line fault check
- One rack space high
- One year limited warranty

#### Other Features:

- Remote control operation
- Standard rear panel RCA connectors and 2 screw terminals

#### Specifications:

Dimensions	19" L x 10" D x 1 3/4" H
Weight	10 lbs.
Quality	Black powder coated chassis, black anodized aluminum front panel
Electrical	120V, 50/60 Hz, single phase
Max. amps	20/unit
Max. watts	2400/unit
Max. front outlet	15 amps
Spike/surge protection	Line to neutral, neutral to ground, line to ground
Clamping level	200V peak
Response time	1 nanosecond
Max. surge voltage	6000V
Max. surge current	26,000 amps
Max. spike energy	630 joules total
Noise attenuation	Transverse greater than 20 dB, 1.5 kHz to 200 MHz
Certification	ETL listed



The PD11SS is a sequential four step/stage power up/down conditioned power distribution unit. It is designed to protect electronic equipment that requires a time-delayed start-up, particularly when high in-rush current can potentially damage audio, video, or computer equipment at power up.

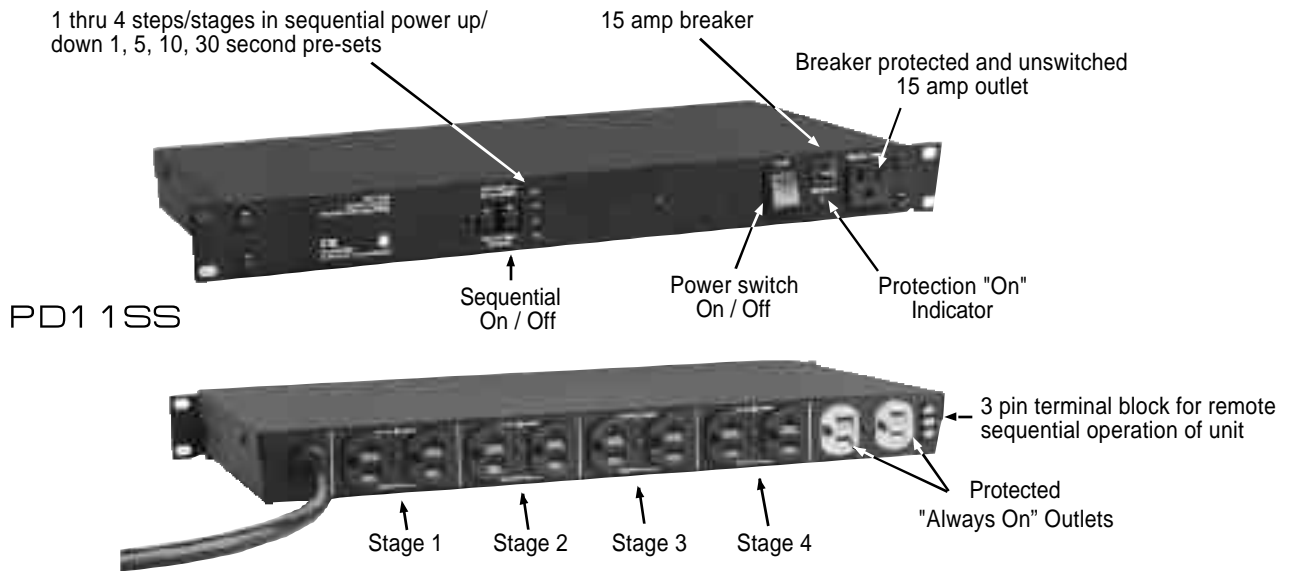

**PD11SS Features:**

- Microprocessor monitored sequential power distribution system
- Four power up/down steps or stages of distributed and conditioned power
- Four pre-set power up/down intervals of 1, 5, 10 or 30 seconds
- Optional manual settings for up to 240 seconds between intervals
- One dual 15 amp U-grounded outlet per stage
- One dual 15 amp "always on" U-grounded outlet
- Full 15 amps, 1800 watts capacity per unit
- 12-gauge, 3-prong, 6-foot, 15-amp power cord
- Protected "always on" 15 amp AC power outlet on the front panel
- Total unit 15 amp outlet circuit breakers located on front panel
- Three-stage spike and surge protection
- EMI/RFI filtration
- Watch dog circuitry with "Go/No Go" L.E.D. display
- One rack space high
- One year limited warranty

**Other Features:**

- Remote control operation  
Access to remote feature is internal to three PC board mounted screw terminals for 3-wire hook-up.

**Specifications:**

Dimensions	19" L x 10" D x 1 3/4" H
Weight	10 lbs.
Quality Finish	Black powder coated chassis, black anodized aluminum front panel
Electrical	120V, 50/60 Hz, single phase
Max. amps	15/unit
Max. watts	1800/unit
Max. front outlet	15 amps
Spike/surge protection	Line to neutral, neutral to ground, line to ground
Clamping level	200V peak
Response time	1 nanosecond
Max. surge voltage	6000V
Max. surge current	12,000 amps
Max. spike energy	450 joules total
Noise attenuation	Transverse > 35 dB, 1.5 kHz to 200 MHz
Certification	ETL listed

- PD1 1P
- PD1 1VP
- PD1 1LP
- PD1 1LVP
- PD1 1LVSP

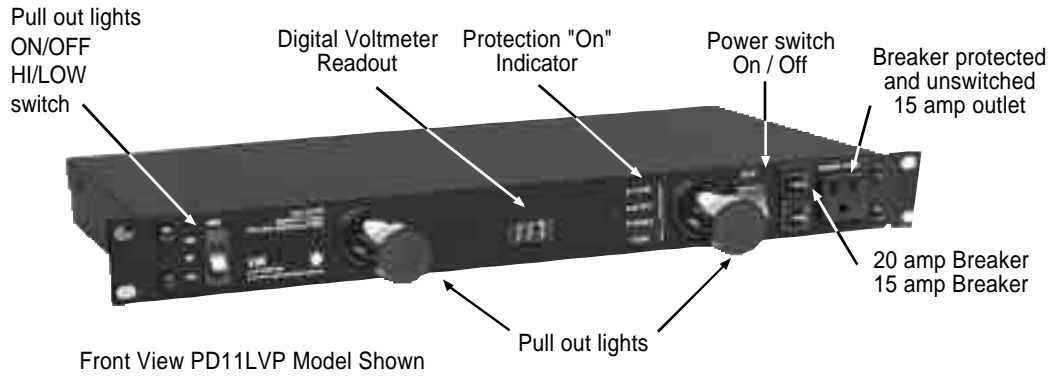

Front View PD11LVP Model Shown

Back View PD11P, 11VP, 11LP, 11LVP



Back View PD11LVSP

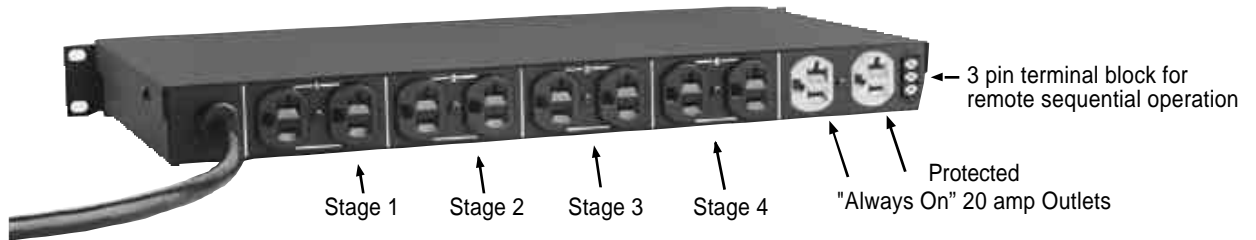

Easy 4-step bulb replacement. Use 120 volt 4 watt bulb (Christmas tree bulb). PD11LP, 11LVP, 11LVSP

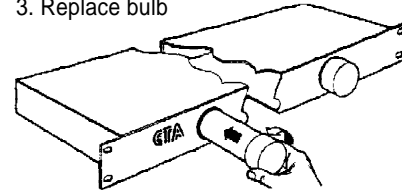
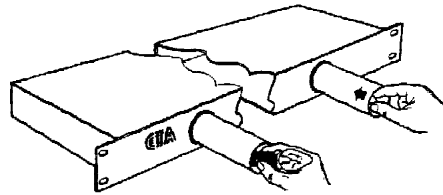
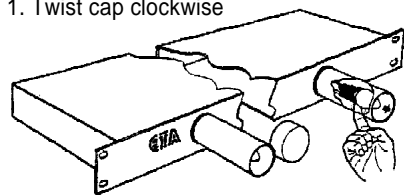
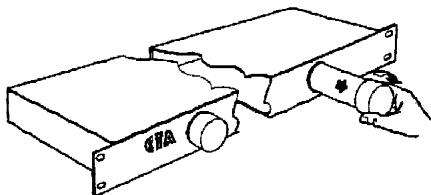

**PD11P, PD11VP, PD11LP, PD11LVP Features:**

- Light Switch (PD11LP/LVP/LVSP) activates rack illumination; choice of HI or LOW intensity
- Light Tubes (PD11LP/LVP/LVSP) illuminates up to 25 rack spaces
- 4 dual 20 amp U-grounded switched outlets per unit
- 1 dual 15 amp U-grounded "always on" and protected outlet
- Digital Voltmeter Readout (PD11VP/LVP/LVSP) displays incoming line voltage
- Resettable 20 amp thermal circuit breaker; 15 amp for front panel outlet
- Lighted Outlet Power Switch activates protection and filtration to all switch outlets and front panel outlet
- 12-gauge, 3-prong, 10-foot, 20-amp power cord. Requires 20 amp circuit and receptacle outlet
- Protected "always on" 15 amp AC power outlet on the front panel
- Total unit 20 amp and 15 amp outlet circuit breakers located on front panel
- Three-stage spike and surge protection
- Two-stage EMI/RFI filtration
- Ground and AC line fault check
- One rack space high
- One year limited warranty

**PD11LVSP Features:**

- Microprocessor monitored sequential power distribution system
- Four power up/down steps or stages of distributed and conditioned power
- Four pre-set power up/down intervals of 1, 5, 10 or 30 seconds
- Optional manual settings for up to 240 seconds between intervals
- One dual 120 amp U-grounded outlet per stage
- One dual 20 amp "always on" U-grounded outlet
- Full 20 amps, 2400 watts capacity per unit
- 12-gauge, 3-prong, 10-foot, 20-amp power cord. Requires 20 amp circuit and receptacle outlet
- Protected "always on" 15 amp AC power outlet on the front panel
- Total unit 20 amp and 15 amp outlet circuit breakers located on front panel
- Three-stage spike and surge protection
- Two-stage EMI/RFI filtration
- Ground and AC line fault check
- One rack space high
- One year limited warranty

**Other Features:**

- Remote control operation
- The remote feature is accessed externally through a 3-wire remote block

**PD11LVSP/LVP/LP/VP/P Specifications:**

Dimensions	19" L x 10" D x 1 3/4" H
Weight	10 lbs.
Quality Finish	Black powder coat chassis, black anodized aluminum front panel
Electrical	120V, 50/60 Hz, single phase
Max. amps	20/unit
Max. watts	2400/unit
Max. front outlet	15 amps
Spike/surge protection	Line to neutral, neutral to ground, line to ground
Clamping level	200V peak
Response time	1 nanosecond
Max. surge voltage	6000V
Max. surge current	23,000 amps (PD11LVSP/LVP/VP/LP/P)
Max. spike energy	630 joules total
Noise attenuation	Transverse > 20 dB, 1.5 kHz to 200 MHz
Certification	ETL listed

## Installation Requirements

### PD11P, PD11VP, PD11LP, PD11SP, PD11LVP, PD11LVSP

Plug unit into power source and observe status of four "Protection" light emitting diodes. The (green) "1st Stage", "2nd Stage", and "GROUND OK" L.E.D.'s should normally be illuminated and the (red) "FAULT" L.E.D. should be off. When these indications are present, test the power "On/Off" switch which will illuminate to indicate that power is being supplied to the switched outlets on the rear of the unit.

- A. The "1st Stage" and "2nd Stage" L.E.D.'s indicate that both the input (1st) and output (2nd) stages of circuit protection are active.
- B. The "GROUND OK" L.E.D. indicates that the chassis is connected to the ground wire of the supply outlet.
- C. Fault conditions are represented by the following indications:

NOTE: (X) = "ON" ( ) = "OFF"

1 <sup>st</sup> Stage	2 <sup>nd</sup> Stage	Ground OK	Fault	
(X)	(X)	(X)	( )	Supply circuit outlet wiring OK
( )	( )	( )	( )	Open hot
( )	( )	(X)	(X)	Open Neutral or Hot & Ground Reversed
(X)	(X)	( )	( )	Open Ground
(X)	(X)	( )	(X)	Hot & Neutral Reversed

**NOTE: On the PD11SS Model** a green L.E.D. located on the front panel is illuminated (indicating "Protection On" status) when unit is plugged into a power source ensuring input and output stages of circuit protection are active.

## Operating Instructions

1. Install in a standard 19" rack or free-standing position.
2. Connect Power Distribution power cord into a 20 amp, 120 volt wall outlet (15 amp for Model PD11SS).
3. Plug sensitive electrical equipment into conditioned outlets. All models have an additional protected outlet on the front panel.
4. Move power outlet switch to "ON" position to provide power to electrical equipment.
5. For illumination, pull out light tubes (PD11LP/LVP/LVSP) and move light switch to "HI" or "LOW" position.  
**IMPORTANT! Be sure light switch is in "OFF" position when light tubes are recessed.**
6. Digital voltmeter readout (PD11VP/LVP/LVSP) is calibrated to nominal 117V at the factory. No adjustment necessary.
7. Digital voltmeter readout automatically displays incoming voltage when power cord is connected.

## Power Problems

Standard AC outlets often supply raw and unprocessed power that not only can diminish the clarity of audio signals and cause premature failure of parts, it can completely destroy your valuable equipment.

Power problems such as spikes, line surges and noise interference transmit through all standard electrical lines and affect power quality: therefore, affecting you.

## Solutions

Conditioned Power Distribution can eliminate such problems from affecting you. As it filters the line voltage from your AC outlets, eliminating noise and interference, such as radio frequency interference (RFI) and electromagnetic interference (EMI), it will reduce the residual noise in the system, which will enhance audio clarity.

Audio Conditioned Power Distribution is also designed to protect electronic equipment from potentially damaging high-voltage spikes and surges.

Sequencing Audio Conditioned Power Distribution is designed to initiate a turn-on cycle, energizing one circuit immediately with remaining circuits energizing in a delayed fashion. This allows circuits to stabilize when powering up and down eliminating that on-rush of power and potential damage to equipment at output receptacle.

### Quick Step Pre-Set Selection for Sequential Models

- Step 1:* Hold down OFF/ON switch simultaneously until L.E.D.'s flash together. If unit was previously set in a manual mode, all channel L.E.D.'s will be ON rather than ON/OFF L.E.D. flashing. Assume they are flashing and proceed to next step.
- Step 2:* While flashing, press ON button to step through the four (1,5,10,30 seconds) pre-sets.
- Step 3:* Stop on desired pre-set.
- Step 4:* Press OFF/ON switch simultaneously.
- Step 5:* To test sequential selection press ON button.
- Step 6:* Press OFF button to return to sequential OFF Position.

### Quick Step Manual Selection

- Step 1:* Hold down OFF/ON switch simultaneously until L.E.D.'s flash together. If unit was previously set in a manual mode, all L.E.D.'s will be ON rather than ON/OFF L.E.D. flashing. Assume they are flashing and proceed to next step.
- Step 2:* While flashing, press ON button to step through the four (1,5,10,30 seconds) pre-sets.
- Step 3:* Stop at channel four (4).
- Step 4:* Press ON button one more time. All channel L.E.D.'s should now be lighted.
- Step 5:* Press ON to start time sequence from 5 to 240 seconds. Press OFF to stop time sequence. (Exits at 240 seconds.)
- Step 6:* To test manual sequential selection press ON button.
- Step 7:* Press OFF button to return to sequential OFF position.

### Quick Step To Clear Unit

- Step 1:* Hold down OFF/ON switches simultaneously until L.E.D.'s flash together. If unit was previously set in a manual mode, all L.E.D.'s will be ON rather than ON/OFF L.E.D. flashing. Assume they are flashing and proceed to next step.
- Step 2:* Step through channels stopping at one or 1 second.
- Step 3:* Press OFF/ON switches together.
- Step 4:* Test — same as above

### Three-Wire Remote Control Interface

A three-wire remote control interface is added to the main PC board for the PD11SS, PD11SP AND PD11LVSP units. This remote control interface is accessible through an external terminal block on the back of the unit (see Figure 6). This interface requires an external user provided switch, L.E.D., and a three-wire cable to implement. The interface has been tested reliably over 1000 feet with 22-gauge speaker wire (see Figures 1 and 5).

Connect the short minus (-) lead of the L.E.D. and one side of the switch to the COMMON terminal, the long plus (+) lead of the L.E.D. to the L.E.D. terminal, and finally the other side of the switch to the ON/OFF terminal. When you close the switch, the L.E.D. will begin flashing until all channels have sequenced ON, and then the L.E.D. will remain ON. When you open the switch the L.E.D. will begin flashing until all channels have sequenced OFF and then the L.E.D. will remain OFF.

### Remote Relay Function Operation (optional)

Using a set of relay contacts that are normally open instead of a switch you can control the PD11SS, PD11SP AND PD11LVSP units with a relay. When you apply power to the relay the channels will sequence ON, and when you disconnect power from the relay the channels will sequence OFF. This allows you to interface a PD11SS, PD11SP AND PD11LVSP unit with other equipment that has dry (normally open) relay contacts (see Figure 2).

### Larger Installations

In a larger installation, you can control different equipment racks from a remote location by running three-wire cable from each rack back to the remote location. Then attach an L.E.D. and switch as before, these would be mounted in the user's control panel, and you now have remote control of each rack in a single location (see Figure 3).

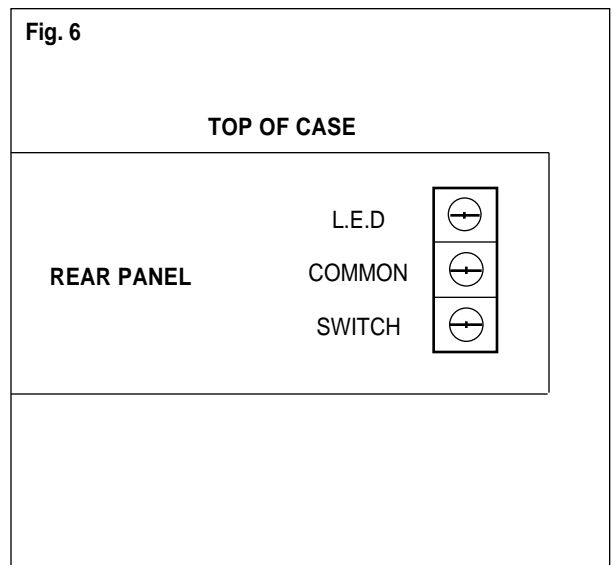
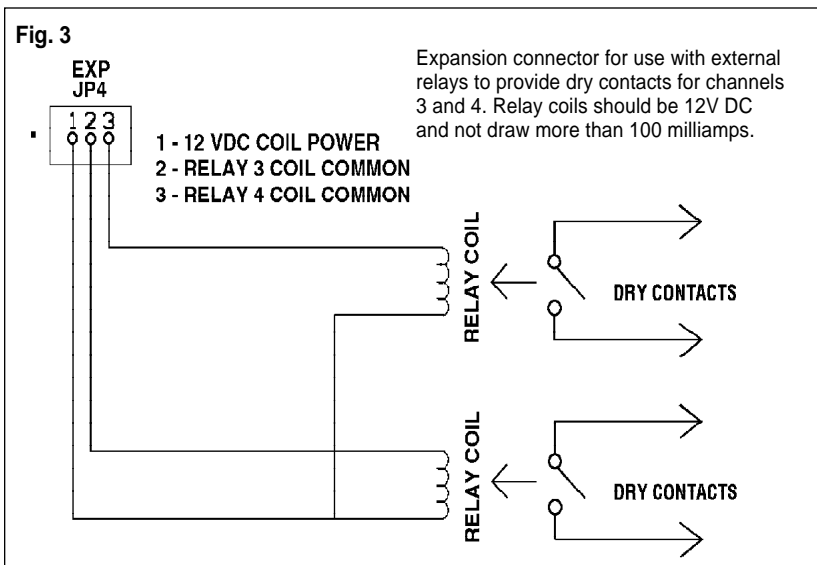
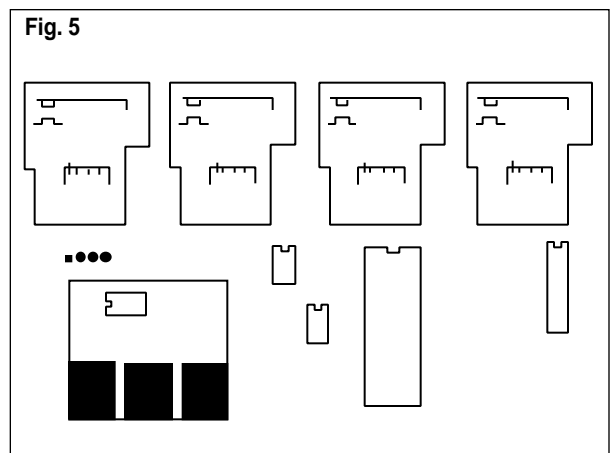
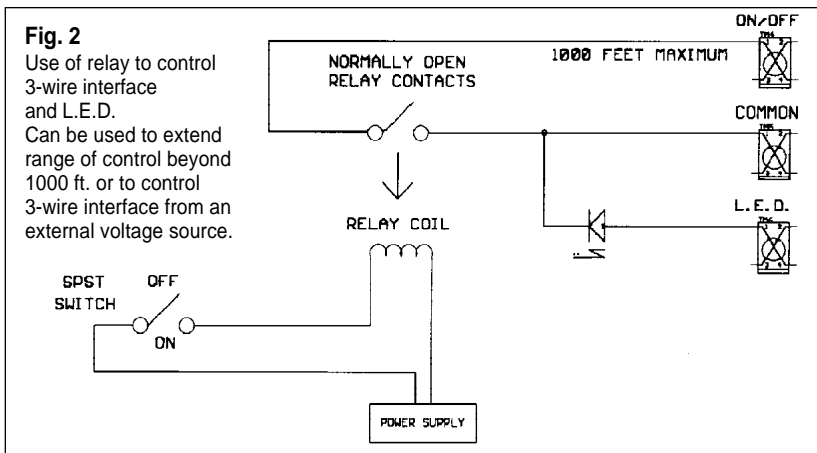
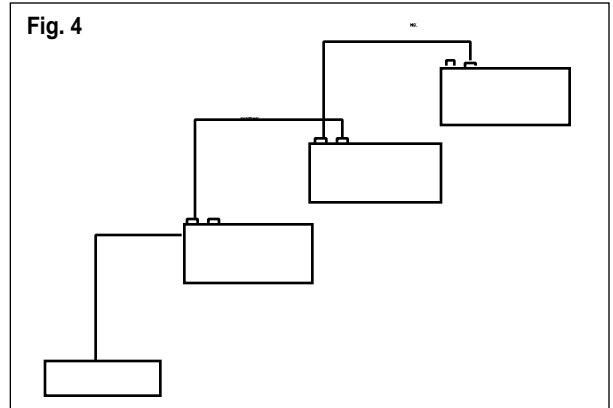
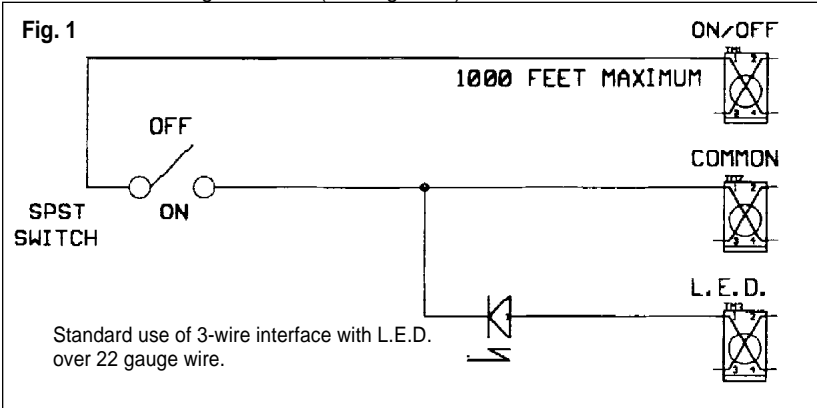

# ETA Conditioned Power Distribution...

## The Benchmark By Which Professionals Compare.

For over 20 years ETA has developed, manufactured and sold high amperage theatrical lighting systems from which evolved an extensive line of rack mounted conditioned power distribution products designed to protect today's sensitive electronic digital equipment.

The "PD" Conditioned Power Distribution Series easily deals with normal AC line power fluctuations, as well as the more drastic abnormalities of the spike and surge variety. Also, filtering of airborne interferences caused by electromagnetic and radio frequency transmissions is routinely accomplished. More sophisticated ETA models utilize microprocessor technology to regulate AC power and sequence power turn-on—reducing high in-rushes of power.

ETA's sophisticated electronic protection technology is the favorite of professional who demand flawless operation of digital mixers, processors, amplifiers and PCs—whether in the studio, in the boardroom, on tour, or in a home entertainment environment.



### Thank you for choosing ETA Systems Power Distribution

Drawing upon our 20 years of solving high-amperage lighting needs and listening to customers' concerns, we have developed a most extensive line of Audio Conditioned Power Distribution. As the problems inherent with AC power increase, you will find ETA providing solutions.

Call 1-800-321-6699 for a Full Line Brochure

## Power Conditioning Firsts from ETA

- "Always-On" Protected Outlets
- 10 Rear Panel Outlets
- Front Panel Convenience Outlets
- Digital Voltmeter Display Readouts
- Microprocessor Managed Voltage Regulators
- Programmable and Linkable Sequential Turn-on Models
- Models Adaptable for Multiple AC Adapters
- High Amp Conditioned Models
- Easy Bulb Change Feature

## Standard on Every ETA Power Conditioning Model

- Spike and Surge Protection and EMI/RFI Filtration on All Three Legs of the Incoming AC Power—A Must to Ensure Protection of Electronic Components and Equipment.

## Typical Uses

All Professional Permanent Installations, Recording Studios, Theatres, Schools, Clubs, Churches, any entertainment venue, business board rooms, and audio/visual multi-use presentation rooms.

**Portable Applications:** On-The-Road Concert Tours, Bands, and D.J. services.

**Other Important Applications:** A/V racks, computer networks, and home entertainment centers.

**ETA** SYSTEMS

*A Creative Light & Sound Company*

1532 Enterprise Parkway • Twinsburg, Ohio 44087  
330-425-3388 • 800-321-6699 • Fax: 330-425-9700  
<http://www.etasys.com> E-mail [eta@etasys.com](mailto:eta@etasys.com)

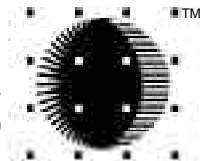



# USB 2.0 LR 4-Port Extender



GTB-USB2.0-4LR



GTB-USB2.0-4LR-BLK

## Extend USB 2.0 over CAT5 up to 330 feet (100 meters)

The GefenToolBox USB 2.0 4-Port Extender extends a USB source up to 330 feet (100 meters) using a single CAT5 cable. This product supports USB 2.0 with data rates up to 480 Mbps in addition to backward-compatibility with USB 1.1. The Receiver Unit allows the connections of up to four (4) USB devices, providing access to printers, scanners, cameras, external storage media, digital signage, and automated control systems.

## How It Works

Use the supplied USB cable to connect the USB 2.0 4-Port Sender Unit to the USB host (source) device. Connect the USB devices to the Receiver Unit. Use a CAT-5 cable to connect the Sender Unit to the Receiver Unit. Connect the included locking power supply to the Receiver Unit then connect both power cables to available electrical outlets. The LED indicators on the Sender Unit and the Receiver Unit provide status on power and data transmission activity.

## Features

- Extends USB 2.0 up to 330 feet (100 meters)
- Supports 480 Mbps using USB 2.0
- Backward-compatible with USB 1.1 devices
- Receiver supports up to four (4) USB devices
- Uses industry-standard CAT-5, CAT-5e, or CAT-6 cable
- Plug-and-Play
- Works with PC and Mac computers
- Locking Power Connectors

## Specifications

- USB 2.0 Speed: 480 Mbps
- USB Connector (Sender Unit): Type B
- USB Connectors (Receiver Unit): (4) Type A
- Link Connectors (Sender Unit / Receiver Unit): RJ-45
- Power Supply: 5V DC locking type (20W max)
- Operating Temperature: +32°F to +122°F (0°C to +50°C)
- Storage Temperature: -4°F to 158°F (-20°C to 70°C)
- Operating Humidity: 20% to 80% relative humidity, non-condensing
- Storage Humidity: 10% to 90% relative humidity, non-condensing
- Dimensions (Sender Unit / Receiver Unit): 5.75" W x 1.25" H x 2.5" D
- Shipping Weight: 3 lbs.

# ERK Series

## enclosure

The ERK Series 19" welded stand-alone / gangable enclosures. Advanced manufacturing techniques provide highest quality and lowest price.

### features:

- Fully welded construction
- 2,500 lb. weight capacity
- 1/8" thick structural steel internal braces
- UL Listed in the US and Canada
- Seismic certified (when used with ERK-Z4 option) with an Ip value of 1.5
- 22" OD width, available 20", 25" or 28" OD depth
- 1/2", 3/4", 1" & 1-1/2" electrical knockouts on removable split rear plates top and bottom, easily removable for cable pass-through. Top plates additionally include UHF / VHF knockouts
- Standard front, optional rear 11-gauge 10-32 threaded, fully adjustable rackrail with numbered rackspace increments
- Keylocked solid rear door standard, optional vented rear doors available
- Optional front doors available
- Configurable top options on 44, 40, and 35 space sizes
- Durable black textured powder coat finish



ERK-4425

### specifications:

EIA compliant 19" stand-alone / gangable equipment rack shall be Middle Atlantic Products model # ERK-\_\_\_-\_\_\_ (see chart for available models). Overall dimensions of rack shall be \_\_\_"H x \_\_\_"W x \_\_\_"D (refer to chart). Useable height shall be \_\_\_ rackspaces, useable depth shall be \_\_\_" (refer to chart). Rack shall be of fully welded construction. Weight capacity shall be 2,500 lbs. ERK shall be finished in a durable black powder coat. ERK shall come equipped with one pair of fully adjustable 11-gauge steel rackrail with tapped 10-32 mounting holes in universal EIA spacing, black e-coat finish and numbered rackspaces. ERK shall include solid locking rear door standard and solid sides with vertical slotted vent pattern at top and bottom (and laser knockouts for cable pass-through on 44, 40, and 35 space models). Top and bottom of ERK shall feature vertical slotted vent pattern. ERK shall have removable split rear knockout panels with 1/2", 3/4", 1", and 1-1/2" electrical knockouts installed in base and a removable rear knockout panel with 1/2", 3/4", 1", and 1-1/2" electrical knockouts and BNC knockouts for UHF/VHF antennae installed in top. Grounding and bonding stud shall be 1/4-20 threaded (1 location), bonding stud shall be 10-32 threaded (3 locations). ERK Series enclosures shall satisfy the 2005 & 2010 Editions of ASCE Standard 7; 2006, 2009 & 2012 editions of the IBC; 2007, 2010 & 2013 editions of the CBC; 2010 editions of the NBC and 2012 edition of the BCBC for use in areas of high seismicity, Occupancy Category IV facilities. Seismic design force is an assumed Site Class D soil conditions, and top floor or rooftop installations. Design for High Importance or Post-disaster installation uses an importance factor (Ip or Ie) of 1.5 when used with ERK-Z4 seismic floor anchor bracket. ERK shall be UL Listed in the US to UL2416 (NWIN) and Canada to CSA C22.2 No. 60950-1. ERK shall be GREENGUARD Gold Certified. ERK Series shall meet the RoHS EU Directive 2011/65/EU. ERK shall be manufactured by an ISO 9001 and ISO 14001 registered company. ERK shall be warranted to be free from defects in material or workmanship under normal use and conditions for the lifetime of the product.

Customizable specification clips available at [middleatlantic.com](http://middleatlantic.com)



PRODUCT CERTIFIED FOR LOW CHEMICAL EMISSIONS  
UL.COM/GG  
UL 2818



### options:

- Front doors shall be model #FD-XX (solid), VFD-XX (vented, 22% open area), LVFD-xx (vented 63% open area-not available for 27 space rack) PVFD-44 (vented plexi), (X=# of rackspaces of ERK rack)
- Rear door, vented, shall be ERK-VRD-XX, Cable management shall be ERK-RDC-XX (XX= # of rackspaces of ERK Rack)
- Top panels for 35, 40 or 44 space ERK, multiple styles available including model #ERK-ST (solid), ERK-10FT (10" fan), ERK-6FT (two 6" fans) ERK-4FT (three 4-1/2" fans), ERK-VT (vented) and ERK-LVT (large perf vented) see A&E spec 96-01063 for more details
- Caster base, four casters shall have a total weight capacity of 1300 pounds, model # CBS-ERK-YY (Y= cabinet depth), raises racks 3.9" (commercial grade) or 4.1" (fine floor)
- Rear rail kit, 11-gauge, 10-32 threaded, sold in pairs, hardware included, model #ERK-RRXX (X=# of rackspaces)
- Seismic compliancy floor anchor kit, model # ERK-Z4
- 18, 21 and 27 space ERK come preconfigured with solid top that includes knockouts to accommodate up to two 4-1/2" fans, or included vent panels
- Optional bonding kit for UL-2416 (NWIN) compliance shall be PET-K-RD (for rear door to enclosure), PET-K-RDC (for cable management rear door to enclosure), PET-K-EXT (for extender bay to enclosure)
- Extender bay adds 3" of usable depth, front mount shall be ERK-(44, 40)-F-EXT3, rear shall be ERK-(44,40)-R-EXT3
- Grommet for 4" electrical knockout in side of ERK shall be model # GK4 and include 4 pieces
- Gland grommet for 4" electrical knockout in side of ERK shall be model #GK-4G. 4 Pieces.
- Slide out option available (See AXS Spec sheet 96-055S)

what **great systems** are built on.™

A brand of **legrand**

**Middle Atlantic Products**  
middleatlantic.com | middleatlantic.com



# ERK Series

## configured A/V enclosure

Configured A/V enclosure ships complete with the most commonly used accessories.

### features:

- Integrated fan top
- Configurable rear door with bottom vent, solid locking front door
- 3-1/4" wide vertical lacer strip (height varies based on model)
- Six horizontal lacer bars
- Twelve 8" Velcro® cable management straps
- Thin power strip, 20 Amp, 20 outlet with cord (44 space enclosures) or 2 qty. thin power strip, 20 Amp, 10 outlet with cord (35 & 40 space enclosures)
- Leveling feet
- 100 qty. 10-32 mounting hardware



ERK-4425-AV

### specifications:

EIA compliant 19" stand-alone / gangable equipment rack shall be Middle Atlantic Products model # ERK-\_\_\_-\_\_\_-AV(see chart for available models). Overall dimensions of rack shall be \_\_\_"H x \_\_\_"W x 25"D (refer to chart). Useable height shall be \_\_\_ rackspaces, useable depth shall be 23-1/2". Rack shall be of fully welded construction. Weight capacity shall be 2,500 lbs. ERK shall be finished in a durable black powder coat. Solid front door and vented, locking and latching rear door and all structural elements shall be finished in a durable black powder coat. Rack shall come equipped with two pairs of 11-gauge steel rackrail with tapped 10-32 mounting holes in universal EIA spacing, black e-coat finish and numbered rackspaces. Rack shall include 100 qty. 10-32 mounting screws. Rack shall be equipped with one 3-1/4" vertical lacer strip Middle Atlantic Products model # LACE-\_\_\_-OP (refer to chart), four 'L' shaped straight and two 4" offset horizontal lacer bars and twelve, 8" Velcro® straps for cable management. The ERK shall have a solid locking rear door standard and solid side panels with vertical slotted vent pattern at top and bottom with laser knockouts for cable pass-through. Rack shall have feature integrated fan top, Middle Atlantic Products model # ERK-4FT-285CFM for active thermal management. The ERK-4FT-285CFM shall consist of three 4-1/2" fans and airflow shall be 285 CFM. Rack shall have removable split rear knockout panels with 1/2", 3/4", 1" and 1-1/2" electrical knockouts and top BNC knockouts for UHF/VHF antennae. Grounding and bonding stud shall be 1/4-20 threaded (1 location), bonding stud shall be 10-32 threaded (3 locations). ERK Series enclosures shall satisfy the 2005 & 2010 Editions of ASCE Standard 7; 2006, 2009 & 2012 editions of the IBC; 2007, 2010 & 2013 editions of the CBC; 2010 editions of the NBC and 2012 edition of the BCBC for use in areas of high seismicity, Occupancy Category IV facilities. Seismic design force is an assumed Site Class D soil conditions, and top floor or rooftop installations. Design for High Importance or Post-disaster installation uses an importance factor (Ip or Ie) of 1.5 when used with ERK-Z4 seismic floor anchor bracket. ERK-\_\_\_-AV shall include a high-density thin power distribution and shall be Middle Atlantic Products model # PDT-\_\_\_-NS with \_\_\_ outlets and 20 amps (refer to chart). Thin power distribution shall be \_\_\_" long (refer to chart) x 1" deep x 1.9" wide. J-Box shall be 2" deep x 2" wide. Thin power distribution shall feature \_\_\_ NEMA 5-20R outlets. Corded power strip includes 20 amp protection and mounting hardware. Corded model shall be terminated with 10-foot power cord and a NEMA 5-20P plug. PDT Series shall feature a black anodized finish. ERK shall be UL Listed in the US to UL2416 (NWIN) and Canada to CSA C22.2 No. 60950-1. ERK shall be GREENGUARD Gold Certified. ERK shall be RoHS EU Directive 2002/95/EC and 2011/65/EU compliant. ERK shall be manufactured by an ISO 9001 and ISO 14001 registered company. ERK shall be warranted to be free from defects in material or workmanship under normal use and conditions for the lifetime of the product.

Customizable specification clips available at [middleatlantic.com](http://middleatlantic.com)



PRODUCT CERTIFIED FOR  
LOW CHEMICAL EMISSIONS  
UL.COM/GG  
UL 2818



what great systems are built on.™

# ERK Series

## basic dimensions

all dimensions in inches unless otherwise noted [all dimensions in brackets are in millimeters]

top view of ERK side sectional view

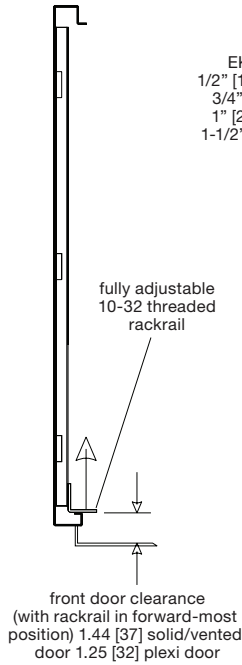

rear view

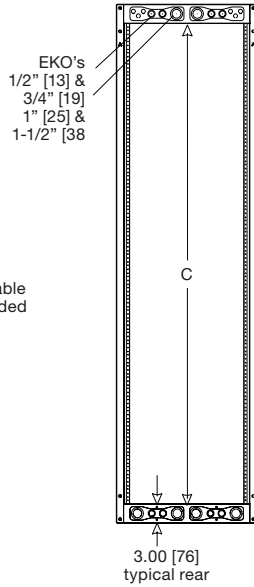

side view

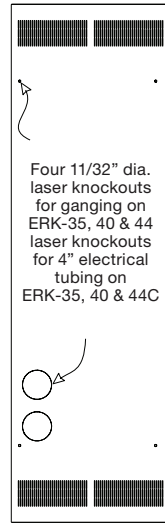

front view

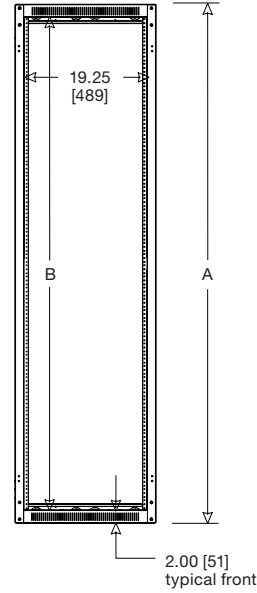

top view ERK-18XX / ERK-21XX / ERK-27XX

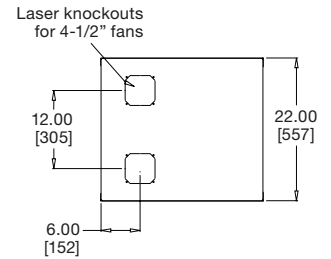

top view ERK-35XX / ERK-40XX / ERK-44XX

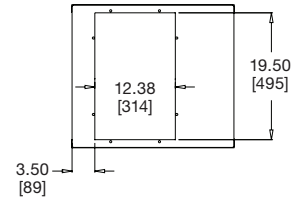

rear view

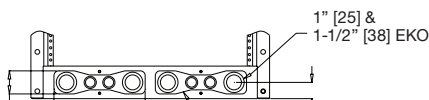
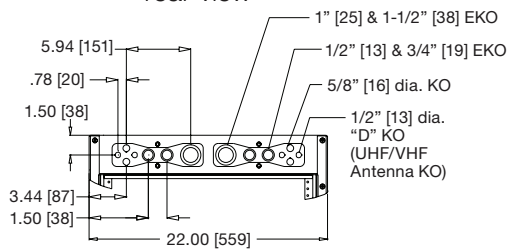

bottom view

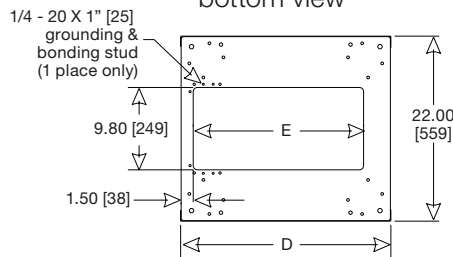

bottom view mounting holes

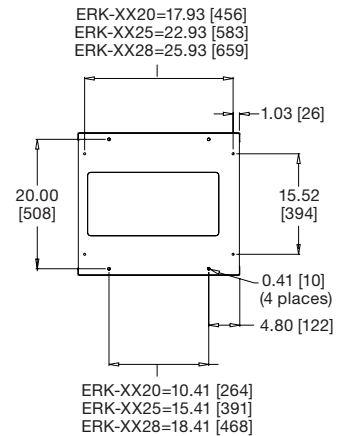

# ERK Series

## basic dimensions

all dimensions in inches unless otherwise noted [all dimensions in brackets are in millimeters]

Part #	A Overall Height	B Useable Height	C Rear Height	D Overall Depth	E Bottom Opening Depth	Useable Depth
ERK-4428	81.130 [2061]	77.130 [1959]	75.130 [1908]	28.00 [711]	23.25 [591]	26.47 [672]
ERK-4028	74.130 [1883]	70.130 [1781]	68.130 [1731]	28.00 [711]	23.25 [591]	26.47 [672]
ERK-3528	65.380 [1661]	61.380 [1559]	59.380 [1508]	28.00 [711]	23.25 [591]	26.47 [672]
ERK-2728	51.380 [1305]	47.380 [1203]	45.380 [1153]	28.00 [711]	23.25 [591]	26.47 [672]
ERK-2128	40.880 [1038]	36.880 [937]	34.880 [886]	28.00 [711]	23.25 [591]	26.47 [672]
ERK-1828	35.630 [905]	31.630 [803]	29.630 [753]	28.00 [711]	23.25 [591]	26.47 [672]
ERK-4425	81.125 [2061]	77.125 [1959]	75.125 [1908]	25.00 [635]	20.25 [514]	23.47 [596]
ERK-4025	74.125 [1883]	70.125 [1781]	68.125 [1703]	25.00 [635]	20.25 [514]	23.47 [596]
ERK-3525	65.375 [1661]	61.375 [1559]	59.375 [1508]	25.00 [635]	20.25 [514]	23.47 [596]
ERK-2725	51.375 [1305]	47.375 [1203]	45.375 [1153]	25.00 [635]	20.25 [514]	23.47 [596]
ERK-2125	40.875 [1038]	36.875 [937]	34.875 [886]	25.00 [635]	20.25 [514]	23.47 [596]
ERK-1825	35.625 [905]	31.625 [803]	29.625 [752]	25.00 [635]	20.25 [514]	23.47 [596]
ERK-4420	81.125 [2061]	77.125 [1959]	75.125 [1908]	20.00 [508]	15.25 [387]	18.47 [469]
ERK-4020	74.125 [1883]	70.125 [1781]	68.125 [1703]	20.00 [508]	15.25 [387]	18.47 [469]
ERK-3520	65.375 [1661]	61.375 [1559]	59.375 [1508]	20.00 [508]	15.25 [387]	18.47 [469]
ERK-2720	51.375 [1305]	47.375 [1203]	45.375 [1153]	20.00 [508]	15.25 [387]	18.47 [469]
ERK-2120	40.875 [1038]	36.875 [937]	34.875 [886]	20.00 [508]	15.25 [387]	18.47 [469]
ERK-1820	35.625 [905]	31.625 [803]	29.625 [752]	20.00 [508]	15.25 [387]	18.47 [469]
ERK-4425-AV	81.125 [2061]	77.125 [1959]	75.125 [1908]	25.00 [635]	20.25 [514]	23.47 [596]
ERK-4025-AV	74.125 [1883]	70.125 [1781]	68.125 [1703]	25.00 [635]	20.25 [514]	23.47 [596]
ERK-3525-AV	65.375 [1661]	61.375 [1559]	59.375 [1508]	25.00 [635]	20.25 [514]	23.47 [596]

### top view (35, 40, and 44 space only)

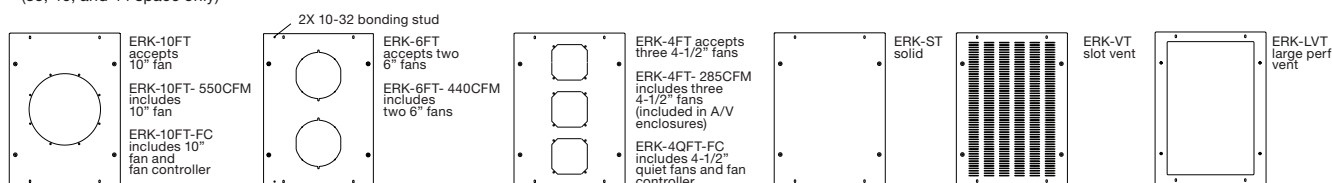

ERK A/V Enclosure Power Distribution

Rack Part #	Part #	Terminated	Circuit	Outlets	Overall Length	Qty
ERK-4025-AV / ERK-3525-AV	PDT-1020C-NS 5-20P	20 Amp	10, 5-20R	37.75 [959]	2	26.47 [672]
ERK-4425-AV	PDT-2020C-NS 5-20P	20 Amp	20, 5-20R	72.75 [1848]	1	23.47 [596]

ERK A/V Enclosure Vertical Lacer Bar Chart

Part #	Lacer Bar	# of Rackspace	Width
ERK-4425-AV	LACE-44-OP	44	3.25 [83]
ERK-4025-AV	LACE-40-OP	40	3.25 [83]
ERK-3525-AV	LACE-37-OP	37	3.25 [83]

what great systems are built on.™

A brand of **legrand**



**Middle Atlantic Products**

middleatlantic.com | middleatlantic.ca

# ERK Series

## basic dimensions

all dimensions in inches unless otherwise noted [all dimensions in brackets are in millimeters]

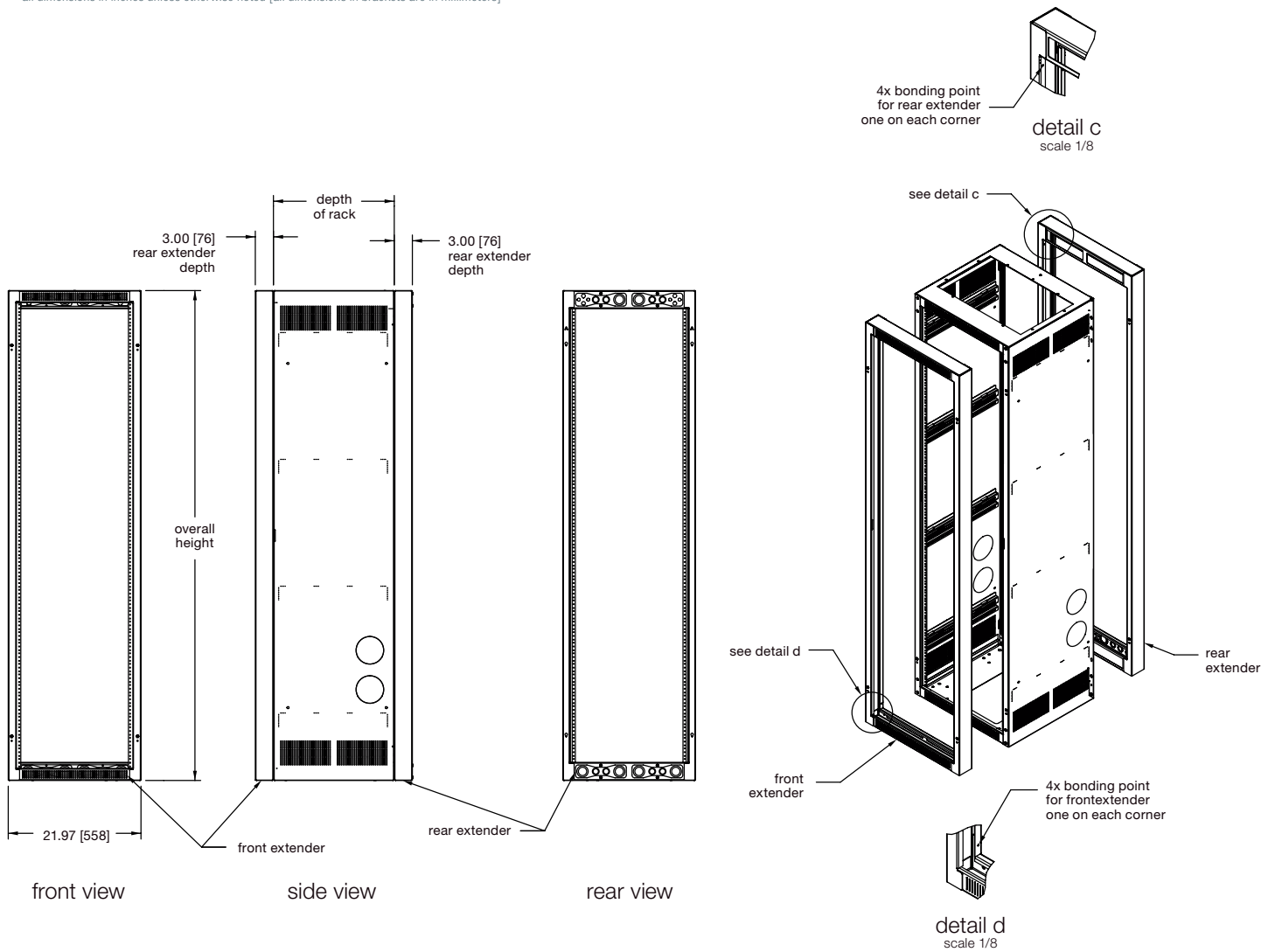

Part #	Rackspaces	Overall Height	Used On	Mounting Location
ERK-44-F-EXT3	44	81.13 [2061]	ERK-44XX	front
ERK-44-R-EXT3	44	81.13 [2061]	ERK-44XX	rear
ERK-40-F-EXT3	40	74.13 [1883]	ERK-40XX	front
ERK-40-R-EXT3	40	74.13 [1883]	ERK-40XX	rear

what **great systems** are built on.™

A brand of **legrand**

**Middle Atlantic Products**

middleatlantic.com | middleatlantic.ca

# ERK Series

## basic dimensions

all dimensions in inches unless otherwise noted [all dimensions in brackets are in millimeters]

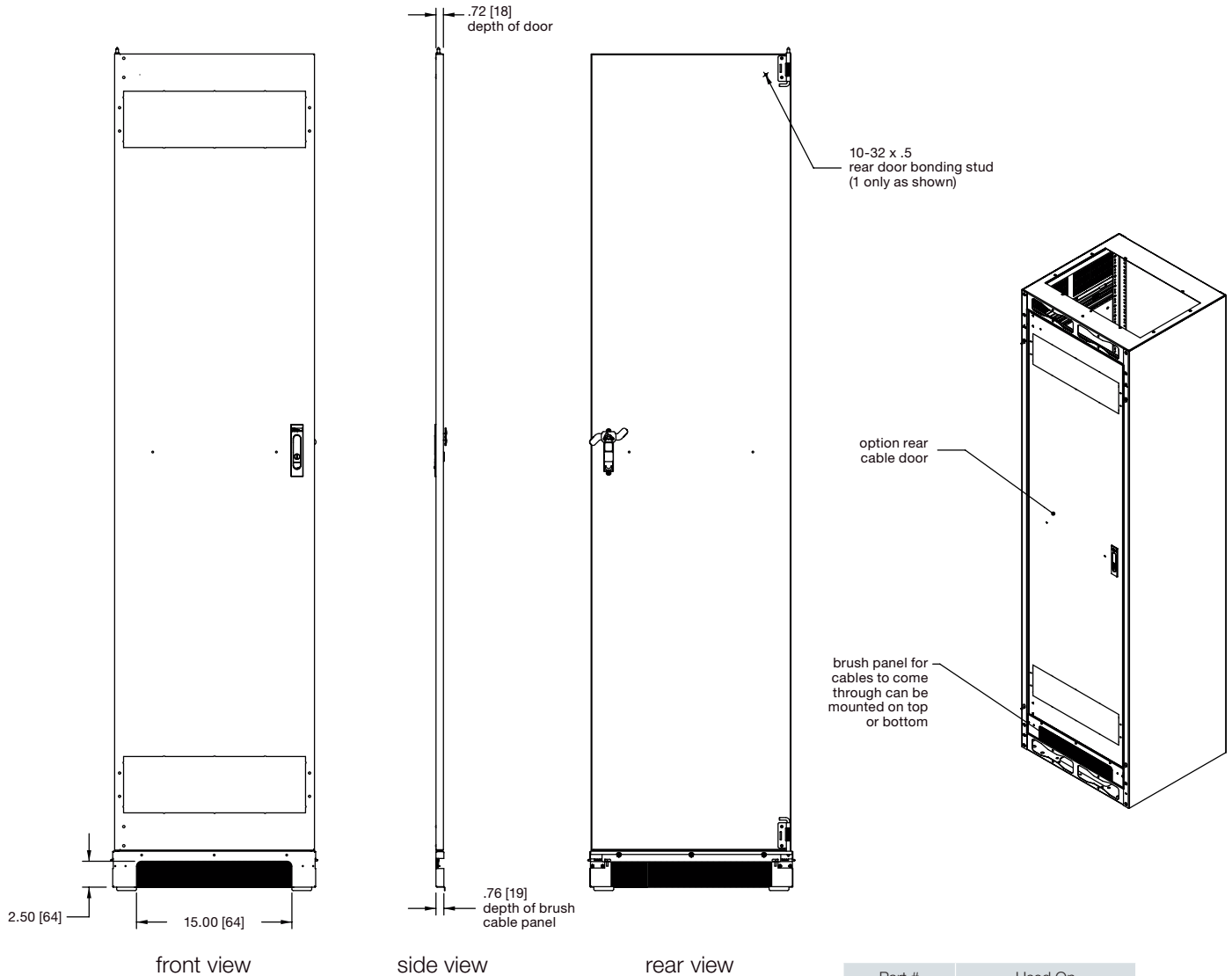

NOTE: Brush panel can be mounted on top or bottom of rack

Part #	Used On
ERK-RDC18	ERK-18XX
ERK-RDC21	ERK-21XX
ERK-RDC27	ERK-27XX
ERK-RDC35	ERK-35XX
ERK-RDC40	ERK-40XX
ERK-RDC44	ERK-44XX

what **great systems** are built on.™

A brand of **legrand**

**Middle Atlantic Products**

[middleatlantic.com](http://middleatlantic.com) | [middleatlantic.ca](http://middleatlantic.ca)

# PDT Series

## thin power distribution

high density power strips feature a slim, low-profile design

### features:

- Slim low-profile design requires minimum space
- Up to 20 outlets depending on model
- Lightweight aluminum chassis
- Field configurable single or dual circuits available in both 15 & 20 amp models
- Field configurable isolated ground models available
- Models available with remote notification of surge protection status
- Models available with local amp metering
- Mounting hardware included
- Corded models include 9' or 20' SignalSAFE™ power cord terminated with NEMA 5-15P / 5-20P / L5-20P plug depending on model
- Black anodized finish
- Top feed models available
- ETL Listed in the US and Canada

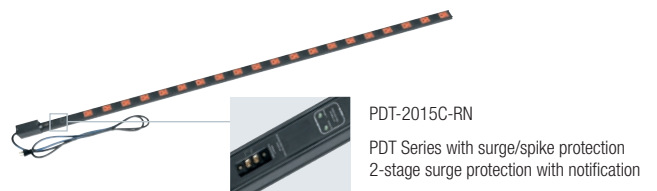
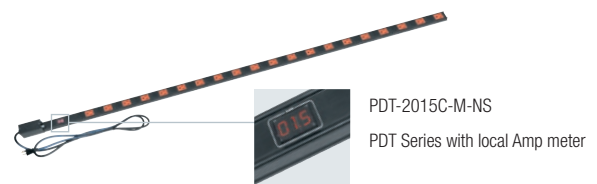

### specifications:

High density thin power distribution shall be Middle Atlantic Products model # PDT-\_\_\_-\_\_\_ with \_\_\_ outlets and \_\_\_ amps (refer to chart). Thin power distribution shall be \_\_\_ long (refer to chart) x 1" deep x 1.9" (20 amp models) or 1.3" (15 amp models) wide. J-Box shall be 2.1" deep X \_\_\_" (refer to chart). Thin power distribution shall feature \_\_\_ NEMA 5-15R / 5-20R outlets (refer to chart). Corded power strip include \_\_\_ amp protection and mounting hardware (refer to chart). Corded models shall be terminated with 9' or 20' SignalSAFE™ power cord and NEMA 5-15P / 5-20P / L5-20P plug (refer to chart). Thin power distribution shall be available with remote notification of surge protection (refer to chart). Thin power distribution shall be available with local amp metering (refer to chart). PDT Series shall feature a black anodized finish. Regular and top feed models shall be provided to accommodate installations where ground prongs must be positioned at the top of each outlet. PDT Series with J-Box shall feature field configurable single or dual circuits available in both 15 & 20 amp models. PDT Series with J-Box shall feature field configurable isolated ground models. PDT shall include a permanently installed supplementary grounding and bonding stud. PDT Series shall be ETL listed to UL Standard 1363 in the US and to CAN/CSA C22.2 #21 in Canada. PDT shall be RoHS EU Directive 2002/95/EC compliant. PDT shall be manufactured by an ISO 9001 registered company. PDT shall be warrantied to be free from defects in material or workmanship under normal use and conditions for a period of three years.

Customizable specification clips available at [middleatlantic.com](http://middleatlantic.com)



what **great systems** are built on.™

A brand of **legrand**

**Middle Atlantic Products**

[middleatlantic.com](http://middleatlantic.com) | [middleatlantic.ca](http://middleatlantic.ca)

96-01031 / rev d / 4-24-18

# PDT Series

## 15 Amp basic dimensions

all dimensions in inches unless otherwise noted [all dimensions in brackets are in millimeters]

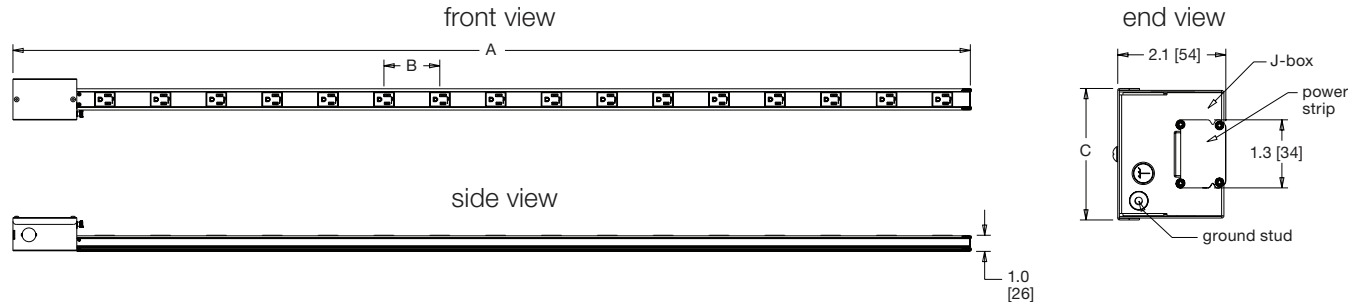

- Notes:
- 1) On corded models allow for a minimum of 2 [51] cord bending space
  - 2) PDT series include SignalSAFE™ power cord technology

Part #	A Overall Length	B Outlet Spacing	C Width	# of Outlets	Ammeter	Surge Protection	Cord Length/ Termination	Outlet Type	Circuit	Isolated Tech. Ground	Overcurrent Protection	J-Box/Cord Location
PDT-615C	29.5 [749]	4.33 [110]	1.58 [40]	6	none	single stage	9' cord w/NEMA 5-15P plug	5-15R	1	no	circuit breaker	bottom
PDT-615C-NS	29.5 [749]	4.33 [110]	1.58 [40]	6	none	none	9' cord w/NEMA 5-15P plug	5-15R	1	no	circuit breaker	bottom
PDT-1015C-NS	37.71 [958]	3.50 [89]	1.58 [40]	10	none	none	9' cord w/NEMA 5-15P plug	5-15R	1	no	circuit breaker	bottom
PDT-1015C-NS20	37.71 [958]	3.50 [89]	1.58 [40]	10	none	none	20' cord w/NEMA 5-15P plug	5-15R	1	no	circuit breaker	bottom
PDT-1015C-RN	37.75 [959]	2.62 [67]	1.58 [40]	10	none	2 stage surge w/status notification	9' cord w/NEMA 5-15P plug	5-15R	1	no	circuit breaker	bottom
PDT-1015C-M-NS	37.75 [959]	2.62 [67]	1.58 [40]	10	yes	none	9' cord w/NEMA 5-15P plug	5-15R	1	no	circuit breaker	bottom
PDT-2X615S	30.00 [762]	2.14 [55]	2.58 [66]	12	none	single stage	j-box	5-15R	1 or 2 (field config)	field config	none	bottom
PDT-1415C	59.5 [1511]	4.00 [102]	1.58 [40]	14	none	single stage	9' cord w/NEMA 5-15P plug	5-15R	1	no	circuit breaker	bottom
PDT-1415C-NS	59.5 [1511]	4.00 [102]	1.58 [40]	14	none	none	9' cord w/NEMA 5-15P plug	5-15R	1	no	circuit breaker	bottom
PDT-1615C-NS	33.50 [851]	1.82 [46]	1.58 [40]	16	none	none	9' cord w/NEMA 5-15P plug	5-15R	1	no	circuit breaker	bottom
PDT-2X815	60.00 [1524]	3.50 [89]	2.58 [66]	16	none	none	j-box	5-15R	1 or 2 (field config)	field config	none	bottom
PDT-2015C-M-NS	72.72 [1847]	3.09 [79]	1.58 [40]	20	yes	none	9' cord w/NEMA 5-15P plug	5-15R	1	no	circuit breaker	bottom
PDT-2015C-RN	72.72 [1847]	3.09 [79]	1.58 [40]	20	none	2 stage surge w/status notification	9' cord w/NEMA 5-15P plug	5-15R	1	no	circuit breaker	bottom
PDT-2015C-NS	72.72 [1847]	3.50 [89]	1.58 [40]	20	none	none	9' cord w/NEMA 5-15P plug	5-15R	1	no	circuit breaker	bottom
PDT-2X1015	73.25 [1861]	3.50 [89]	2.58 [66]	20	none	none	j-box	5-15R	1 or 2 (field config)	field config	none	bottom
PDT-2X1015T	73.25 [1861]	3.50 [89]	2.58 [66]	20	none	none	j-box	5-15R	1 or 2 (field config)	field config	none	top
PDT-2X1015TS	72.75 [1848]	3.50 [89]	1.58 [40]	20	none	none	j-box	5-15R	1 or 2 (field config)	field config	none	top

what great systems are built on.™

A brand of **legrand**

**Middle Atlantic Products**

middleatlantic.com | middleatlantic.ca

# PDT Series

## 20 Amp basic dimensions

all dimensions in inches unless otherwise noted [all dimensions in brackets are in millimeters]

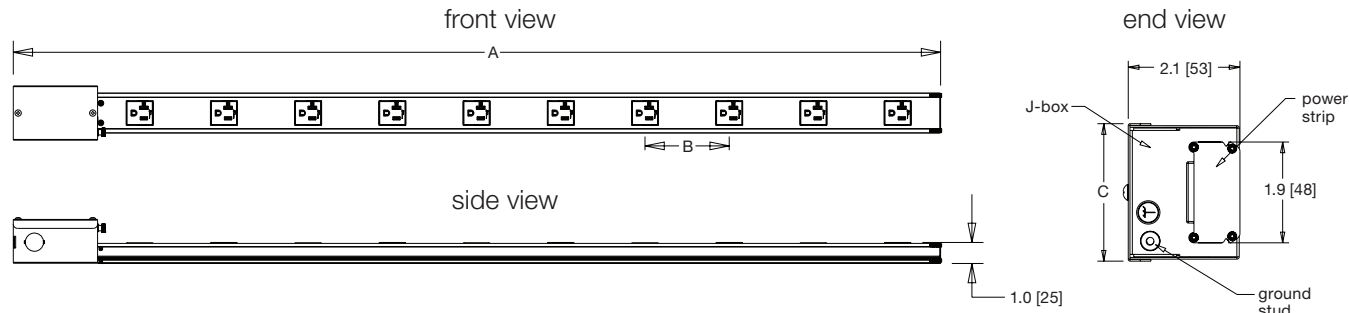

- Notes:
- 1) On corded models allow for a minimum of 2 [51] cord bending space
  - 2) PDT series include SignalSAFE™ power cord technology

Part #	A Overall Length	B Outlet Spacing	C Width	# of Outlets	Ammeter	Surge Protection	Cord Length/ Termination	Outlet Type	Circuit	Isolated Tech. Ground	Overcurrent Protection	J-Box/Cord Location
PDT-620C-NS	29.5 [749]	4.33 [110]	2.13 [54]	6	none	none	9' cord w/NEMA 5-20P plug	5-20R	1	no	circuit breaker	bottom
PDT-2X320	30.00 [762]	4.33 [110]	2.58 [66]	6	none	none	j-box	5-20R	1 or 2 (field config)	field config	none	bottom
PDT-2X520	44.00 [1118]	4.00 [102]	2.58 [66]	10	none	none	j-box	5-20R	1 or 2 (field config)	field config	none	bottom
PDT-1020C-NS	37.75 [959]	3.50 [89]	2.13 [54]	10	none	none	9' cord w/NEMA 5-20P plug	5-20R	1	no	circuit breaker	bottom
PDT-1220C-NS	59.5 [1511]	4.66 [118]	2.13 [54]	12	none	none	9' cord w/NEMA 5-20P plug	5-20R	1	no	circuit breaker	bottom
PDT-2X820	60.00 [1524]	3.5 [89]	2.58 [66]	16	none	none	j-box	5-20R	1 or 2 (field config)	field config	none	bottom
PDT-1620C-NS	33.5 [851]	1.82 [46]	2.13 [54]	16	none	none	9' cord w/NEMA 5-20P plug	5-20R	1	no	circuit breaker	bottom
PDT-2020C-NS	72.75 [1848]	3.50 [89]	2.13 [54]	20	none	none	9' cord w/NEMA 5-20P plug	5-20R	1	no	circuit breaker	bottom
PDT-2020C-RN	72.75 [1848]	3.09 [79]	2.13 [54]	20	none	2 stage surge w/ status notification	9' cord w/NEMA 5-20P plug	5-20R	1	no	circuit breaker	bottom
PDT-2020C-M-NS	72.75 [1848]	3.09 [79]	2.13 [54]	20	yes	none	9' cord w/NEMA 5-20P plug	5-20R	1	no	circuit breaker	bottom
PDT-2020TL-NS	72.75 [1848]	3.50 [89]	2.13 [54]	20	none	none	9' cord w/NEMA L5-20P plug	5-20R	1	no	circuit breaker	bottom
PDT-2020TL-M-NS	72.75 [1848]	3.09 [79]	2.13 [54]	20	yes	none	9' cord w/NEMA L5-20P plug	5-20R	1	no	circuit breaker	bottom
PDT-2X1020	73.25 [1861]	3.50 [89]	2.58 [66]	20	none	none	j-box	5-20R	1 or 2 (field config)	field config	none	bottom
PDT-2X1020T	73.25 [1861]	3.50 [89]	2.58 [66]	20	none	none	j-box	5-20R	1 or 2 (field config)	field config	none	top
PDT-2X1020S	72.75 [1848]	3.50 [89]	2.13 [54]	20	none	none	j-box	5-20R	1 or 2 (field config)	field config	none	bottom
PDT-2X1020TS	72.75 [1848]	3.50 [89]	2.13 [54]	20	none	none	j-box	5-20R	1 or 2 (field config)	field config	none	top

what great systems are built on.™

A brand of **legrand**

**MA**

**Middle Atlantic Products**

middleatlantic.com | middleatlantic.ca



# Caster/Inner Platform Bases

## features:

### Caster Base

- Available in commercial grade or for fine floors
- Durable black textured powder coat finish
- Commercial grade caster base is UL listed in Canada and the U.S. (except Slim 5 models)
- Accommodates MRK, WRK, ERK and Slim 5 Series enclosures



BS-MRK-31

### Inner Platform Base

- Fits inside rack
- Mounts flush with bottom of rackspace
- Ideal for supporting heavy electrical equipment and mounting electrical boxes
- Accommodates MRK and WRK Series enclosures



CBS-MRK-31

## specifications:

### CBS Commercial Grade Caster Base

Commercial grade caster base shall be Middle Atlantic Products model # CBS-\_\_\_-\_\_\_ to accommodate \_\_\_ Series \_\_\_" depth racks (refer to chart). Caster base shall be constructed of 11-gauge steel. Caster base shall be \_\_\_" H x \_\_\_" W x \_\_\_" D and have a weight capacity of \_\_\_ lbs. (refer to chart). Caster base shall have one knockout in the center of the base for cable pass-through measuring \_\_\_" W x \_\_\_" D (refer to chart). Caster base shall raise total rack height \_\_\_" (refer to chart). Caster base shall be finished in a durable textured black powder coat. Caster base shall be UL listed in the U.S. and Canada (except Slim 5 models). Caster base shall be GREENGUARD Gold Certified. Caster base shall comply with the requirements of RoHS EU Directive 2002/95/EC. Caster base shall be manufactured by an ISO 9001 and ISO 14001 registered company. Caster base shall be warranted to be free from defects in material or workmanship under normal use and conditions for a period of 7 years.

### CBS Fine Floor Caster Base

Fine floor caster base shall be Middle Atlantic Products model # CBS-\_\_\_-\_\_\_R to accommodate \_\_\_ Series \_\_\_" depth racks (refer to chart). Caster base shall be constructed of 11-gauge steel. Caster base shall be \_\_\_" H x \_\_\_" W x \_\_\_" D and have a weight capacity of \_\_\_ lbs. (refer to chart). Caster base shall have one knockout in the center of the base for cable pass-through measuring \_\_\_" W x \_\_\_" D (refer to chart). Caster base shall raise total rack height \_\_\_" (refer to chart). Caster base shall be finished in a durable textured black powder coat. Caster base shall be GREENGUARD Gold Certified. Caster base shall comply with the requirements of RoHS EU Directive 2002/95/EC. Caster base shall be manufactured by an ISO 9001 and ISO 14001 registered company. Caster base shall be warranted to be free from defects in material or workmanship under normal use and conditions for a period of 7 years.

### BS Inner Platform Base

Inner platform base shall be Middle Atlantic Products model # BS-\_\_\_-\_\_\_ to accommodate \_\_\_ Series \_\_\_" depth racks (refer to chart). Inner platform base shall be constructed of 11-gauge steel. Inner platform base shall be \_\_\_" H x \_\_\_" W x \_\_\_" D (refer to chart). Inner platform base shall have one knockout in the center of the base for cable pass-through measuring \_\_\_" W x \_\_\_" D (refer to chart). Inner platform base shall be finished in a durable textured black powder coat. Inner platform base shall be GREENGUARD Gold Certified. Inner platform base shall comply with the requirements of RoHS EU Directive 2002/95/EC. Inner platform base shall be manufactured by an ISO 9001 and ISO 14001 registered company. Inner platform base shall be warranted to be free from defects in material or workmanship under normal use and conditions for the lifetime of the product.

Customizable specification clips available at [middleatlantic.com](http://middleatlantic.com)



PRODUCT CERTIFIED FOR  
LOW CHEMICAL EMISSIONS  
UL.COM/GG  
UL 2818

what **great systems** are built on.™

A Group brand | **legrand**

**Middle Atlantic Products**  
middleatlantic.com | middleatlantic.ca

96-936 / rev c / 3-25-15

# CBS-MRK/WRK-XX

## basic dimensions

all dimensions in inches unless otherwise noted [all dimensions in brackets are in millimeters]

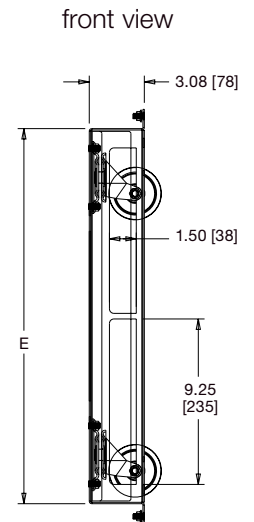
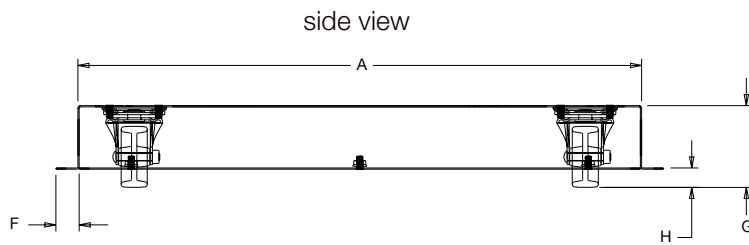
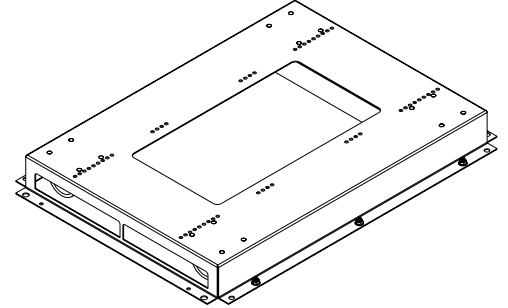
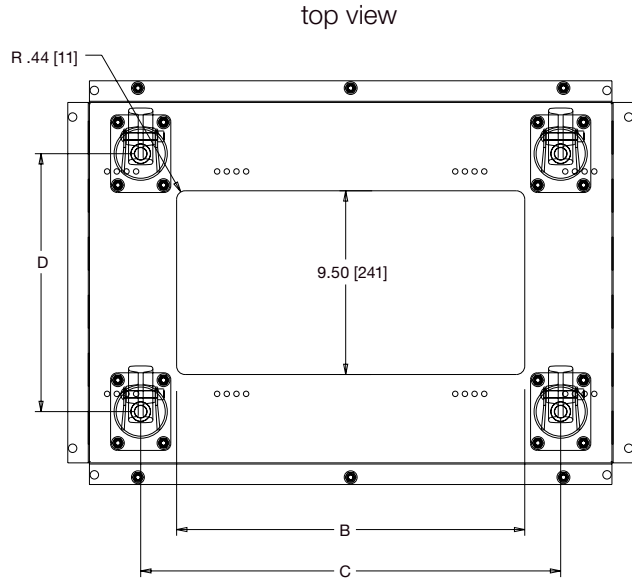

CBS-MRK/WRK-XX Size Chart

Part #	Fits	Grade	A Depth	B Opening Depth	C Caster to Caster Depth	D Caster to Caster Width	E Width	F Flange	G Overall Height	H Height Rack is Raised	Weight Capacity
CBS-MRK-26	MRK- 26" deep	commercial	22.14 [562]	10.84 [275]	16.72 [425]	13.34 [339]	18.76 [476]	1.12 [28]	4.1 [104]	1.0 [25]	1300 lbs.
CBS-MRK-26R	MRK- 26" deep	fine floor	22.14 [562]	10.84 [275]	16.72 [425]	13.34 [339]	18.76 [476]	1.12 [28]	4.1 [104]	1.1 [28]	720 lbs.
CBS-MRK-31	MRK- 31" deep	commercial	27.14 [689]	15.84 [402]	21.72 [551]	13.34 [339]	18.76 [476]	1.12 [28]	4.1 [104]	1.0 [25]	1300 lbs.
CBS-MRK-31R	MRK- 31" deep	fine floor	27.14 [689]	15.84 [402]	21.72 [551]	13.34 [339]	18.76 [476]	1.12 [28]	4.1 [104]	1.1 [28]	720 lbs.
CBS-MRK-36	MRK- 36" deep	commercial	31.74 [806]	20.44 [519]	26.32 [669]	13.34 [339]	18.76 [476]	1.12 [28]	4.1 [104]	1.0 [25]	1300 lbs.
CBS-MRK-36R	MRK- 36" deep	fine floor	31.74 [806]	20.44 [519]	26.32 [669]	13.34 [339]	18.76 [476]	1.12 [28]	4.1 [104]	1.1 [28]	720 lbs.
CBS-WRK-27	WRK- 27" deep	commercial	24.34 [618]	13.00 [330]	18.88 [480]	15.50 [394]	20.97 [533]	1.16 [29]	4.0 [102]	1.0 [25]	1300 lbs.
CBS-WRK-27R	WRK- 27" deep	fine floor	24.34 [618]	13.00 [330]	18.88 [480]	15.50 [394]	20.97 [533]	1.16 [29]	4.2 [107]	1.2 [30]	700 lbs.
CBS-WRK-32	WRK- 32" deep	commercial	29.34 [745]	18.00 [457]	23.88 [607]	15.50 [394]	20.97 [533]	1.16 [29]	4.0 [102]	1.0 [25]	1300 lbs.
CBS-WRK-32R	WRK- 32" deep	fine floor	29.34 [745]	18.00 [457]	23.88 [607]	15.50 [394]	20.97 [533]	1.16 [29]	4.2 [107]	1.2 [30]	700 lbs.

what great systems are built on.™

A Group brand |  legrand

 Middle Atlantic Products

[middleatlantic.com](http://middleatlantic.com) | [middleatlantic.ca](http://middleatlantic.ca)

# CBS-5/ERK-XX

## basic dimensions

all dimensions in inches unless otherwise noted [all dimensions in brackets are in millimeters]

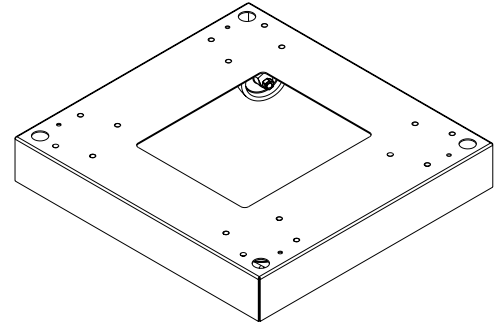
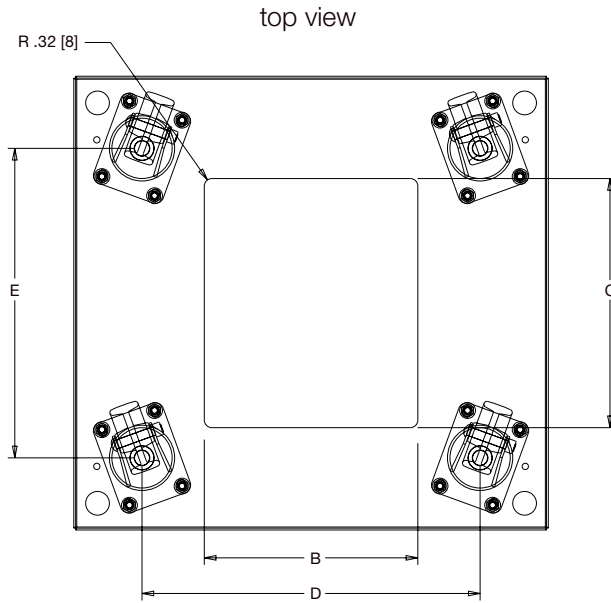

front view

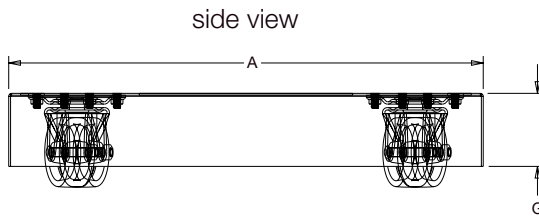
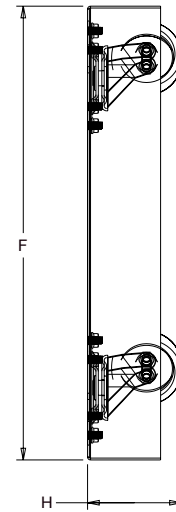

CBS-5/ERK-XX Size Chart

Part #	Fits	Grade	A Depth	B Opening Depth	C Caster to Caster Depth	D Caster to Caster Width	E Width	F Width	G Skirt Height	H Height Rack is Raised	Weight Capacity
CBS-5	Slim 5- 20" deep	commercial	20.00 [508]	9.00 [229]	10.50 [267]	14.25 [362]	13.05 [331]	19.13 [486]	3.08 [78]	3.9 [99]	400 lbs.
CBS-5R	Slim 5- 20" deep	fine floor	20.00 [508]	9.00 [229]	10.50 [267]	14.25 [362]	13.05 [331]	19.13 [486]	3.08 [78]	4.1 [104]	400 lbs.
CBS-5 -26	Slim 5- 26" deep	commercial	26.00 [660]	15.00 [381]	10.50 [267]	20.25 [514]	13.05 [331]	19.13 [486]	3.08 [78]	3.9 [99]	400 lbs.
CBS-5-26R	Slim 5- 26" deep	fine floor	26.00 [660]	15.00 [381]	10.50 [267]	20.25 [514]	13.05 [331]	19.13 [486]	3.08 [78]	4.1 [104]	400 lbs.
CBS-ERK-20	ERK- 20" deep	commercial	20.00 [508]	14.50 [368]	9.80 [249]	13.88 [353]	15.87 [403]	22.00 [559]	3.00 [76]	3.9 [99]	1300 lbs.
CBS-ERK-20R	ERK- 20" deep	fine floor	20.00 [508]	14.50 [368]	9.80 [249]	13.88 [353]	15.87 [403]	22.00 [559]	3.00 [76]	4.1 [104]	700 lbs.
CBS-ERK-25	ERK- 25" deep	commercial	25.00 [635]	19.50 [495]	9.80 [249]	18.88 [480]	15.87 [403]	22.00 [559]	3.00 [76]	3.9 [99]	1300 lbs.
CBS-ERK-25R	ERK- 25" deep	fine floor	25.00 [635]	19.50 [495]	9.80 [249]	18.88 [480]	15.87 [403]	22.00 [559]	3.00 [76]	4.1 [104]	700 lbs.
CBS-ERK-28	ERK- 28" deep	commercial	28.00 [711]	22.50 [572]	9.80 [249]	21.88 [556]	15.87 [403]	22.00 [559]	3.00 [76]	3.9 [99]	1300 lbs.
CBS-ERK-28R	ERK- 28" deep	fine floor	28.00 [711]	22.50 [572]	9.80 [249]	21.88 [556]	15.87 [403]	22.00 [559]	3.00 [76]	4.1 [104]	700 lbs.

what great systems are built on.™

# BS-MRK/WRK-XX

## basic dimensions

all dimensions in inches unless otherwise noted [all dimensions in brackets are in millimeters]

top view

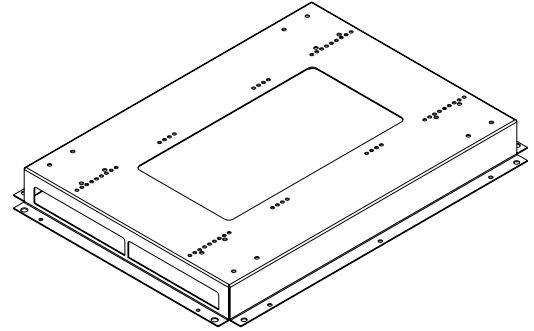
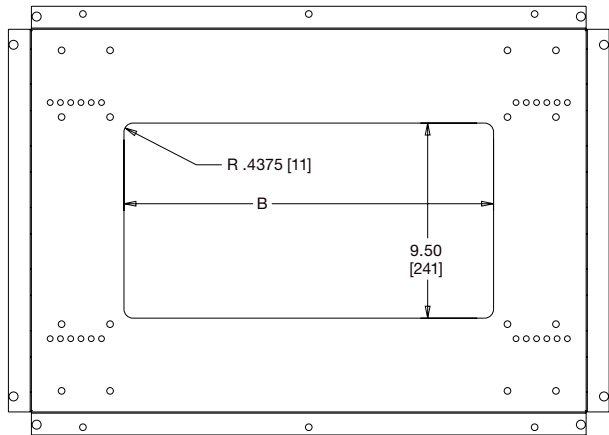

front view

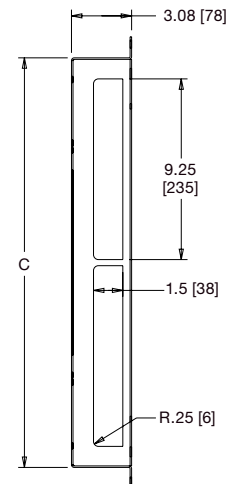

side view

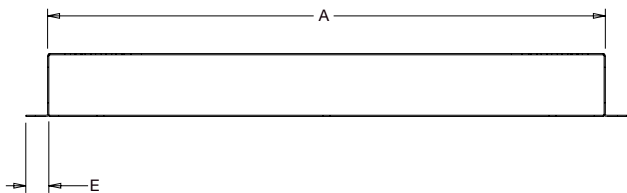

BS-MRK/WRK-XX Size Chart

Part #	Fits	A Depth	B Knockout Depth	C Width	D Height	E Flange
BS-MRK-26	MRK- 26" deep	22.14 [562]	10.84 [275]	18.76 [476]	3.060 [78]	1.120 [28]
BS-MRK-31	MRK- 31" deep	27.14 [689]	15.84 [402]	18.76 [476]	3.060 [78]	1.120 [28]
BS-MRK-36	MRK- 36" deep	31.74 [806]	20.44 [519]	18.76 [476]	3.060 [78]	1.120 [28]
BS-MRK-42	MRK- 42" deep	37.74 [959]	26.44 [672]	18.76 [476]	3.060 [78]	1.120 [28]
BS-WRK-27	WRK- 27" deep	24.343 [618]	17.50 [444]	20.968 [533]	3.078 [78]	1.156 [29]
BS-WRK-32	WRK- 32" deep	29.343 [745]	22.50 [571]	20.968 [533]	3.078 [78]	1.156 [29]

what **great systems** are built on.™

A Group brand | **legrand**

**MA**  
Middle Atlantic Products

middleatlantic.com | middleatlantic.ca



*All models include an integrated security cover for tamper-proof installations*

The 4-channel CX amplifiers give you four channels in only two rack spaces, without compromising on power. Choose from three models, a direct 70 volt model and two low-impedance versions. Each model is equipped with exclusive QSC PowerLight™ switching power supply technology to virtually eliminate noise and hum. With high-output power, versatile loading options, high-thermal capacity and unmatched reliability, the CX Series is the perfect solution to any permanently installed sound system.

### Features

- Three models that range in power from 170 watts to 450 watts per channel
- Compact size – all models only 2 RU and 14" deep for reduced rack cost and floor space
- Channels 1&2 and 3&4 bridgeable for maximum flexibility
- Active Inrush Limiting eliminates AC inrush current, removing the need for expensive power sequencers
- HD15 DataPort connector for QSControl computer control
- Custom integrated security cover for tamper-proof installations
- Variable speed fan for low noise
- 1 dB detented gain controls for fast and accurate gain settings
- Detachable Euro-style input connectors
- DIP switch control for clip limiters, high-pass filters, bridge-mono and parallel operation
- Exclusive PowerLight switch-mode power supply technology for high performance and compact size
- Selectable high-pass filters protect speakers and prevent speaker transformer saturation with minimal effect on program material (33 Hz or 75 Hz on CX254 and CX404, 50 Hz or 75 Hz on CX204V)
- Comprehensive front panel indicators including signal, clip, protect and QSC's exclusive bridge-mono and parallel input LEDs
- Barrier strip output connector
- Comprehensive protection circuitry including DC, infrasonic, thermal overload and short circuit protection
- High-performance Class AB+B complementary bipolar output circuitry
- Lightweight – all models only 21 pounds (9.5 kg) for easier racking and shipping
- 3-year warranty plus optional 3-year extended service contract

### CX 4-channel Amplifiers

Model	70V	Watts per channel		
		8Ω	4Ω	2Ω
CX254	–	170	250	450*
CX404	–	250	400**	–
CX204V	200	–	–	–

20 Hz – 20 kHz, 0.05% THD

\*1 kHz, 1% THD

\*\*1 kHz, 0.1% THD

	<b>CX254</b>	<b>CX404</b>	<b>CX204V</b>
Stereo Mode (all channels driven)		Continuous average output power per channel	
8Ω / 20 Hz – 20 kHz / 0.05% THD	170 W	250 W	–
4Ω / 20 Hz – 20 kHz / 0.05% THD	250 W	400 W (0.1% THD, 1 kHz)	–
2Ω / 1 kHz / 1% THD	450 W	–	–
70V / 20 Hz – 20 kHz / 0.05% THD	–	–	200 W
70V / 1 kHz / 0.05% THD	–	–	220 W
70V / 1 kHz / 1% THD	–	–	300 W
Bridge-Mono Mode		Bridge-mono mode operation	
16Ω / 20 Hz – 20 kHz / 0.1% THD	340 W	500 W	–
8Ω / 20 Hz – 20 kHz / 0.1% THD	500 W	800 W (0.1% THD, 1 kHz)	–
4Ω / 1 kHz / 1% THD	900 W	–	–
140V / 20 Hz – 20 kHz / 0.1% THD	–	–	400 W
140V / 1 kHz / 0.05% THD	–	–	440 W
140V / 1 kHz / 1% THD	–	–	600 W
Noise (20 Hz - 20 kHz)	-106 dB	-106 dB	-105 dB
Input Sensitivity	1.22 Vrms	1.22 Vrms	1.26 Vrms
Gain	29 dB at 8Ω	31 dB at 8Ω	35 dB at 70.7V
Input Clipping	10 Vrms (+22 dBu)	10 Vrms (+22 dBu)	10 Vrms (+22 dBu)
Output Circuitry	Class AB+B	Class AB+B	Class AB+B
Distortion (SMPTE-IM)	< 0.01%	< 0.01%	< 0.02%
Distortion (typical)			
20 Hz – 20 kHz: 10 dB below rated power	< 0.01% THD		
1.0 kHz and below: full rated power	< 0.01% THD		
Frequency Response	20 Hz - 20 kHz, ± 0.2 dB   8 Hz - 50 kHz, + 0/-3 dB		
Damping Factor	> 500 (1 kHz and below)		
Input Impedance	6k ohms unbalanced, 12k ohms balanced		
Cooling	Variable-speed fan / rear-to-front air flow through tunnel heat sink		
Connectors	Input: 3 position Euro style detachable barrier block, Ch 1, 2, 3 & 4 DataPort: HD-15 Connector, Ch 1+2, Ch 3+4 Output: Six-position barrier strip with dual channel and bridge mono connections, Ch 1+2, Ch 3+4		
Controls	Front: AC swith, Ch 1, 2, 3 & 4 gain knobs Rear: DIP switch for Ch 1, 2, 3 & 4, clip limiter on/off, LF filter on/off, LF filter freq select 33 Hz or 75 Hz CX254 and CX 404: 50 Hz or 75 Hz CX204V: inputs parallel or stereo, bridge mode		
Indicators	Parallel Inputs: Yellow LED / Bridged: Yellow LED/ Power-on: Green LED Clip-Prot: Red LED / Level -10dB: Green LED / Level -20dB: Green LED / Signal -35dB: Green LED (1 per channel)		
Amplifier Protection	Full short circuit, open circuit, thermal, ultrasonic, and RF protection. Stable into reactive or mismatched loads		
Load Protection	On/off muting, DC-fault power supply shutdown		
Dimensions (HWD)	3.5" (8.9 cm) 2 RU x 19" (48.3 cm) rack mounting x 14" (35.6 cm) from front mounting rails		
Weight - Net / Shipping	21 lb (9.5 kg) / 27 lb (12.3 kg)		
Power Requirements	100, 120, 230 VAC, 50 – 60 Hz (configured at factory)		
120V Current Consumption*	Idle	0.7 A	0.7 A
1/8 power pink noise (typical of program material at maximum unclipped power)	8Ω	5.8 A	8.1 A
	4Ω	9.2 A	12.4 A
	2Ω	14.3 A	NR
	70V	–	–
1/3 power pink noise (typical of program material with severe clipping)	8Ω	8.8 A	12.2 A
	4Ω	14.2 A	19.3 A
	2Ω	21.7 A	NR
	70V	–	–
			12.7 A

\* Multiply currents by 0.5 for 230V units



Specifications subject to change without notice.

QSC, the QSC logo and PowerLight are registered trademarks of QSC Audio Products, LLC in the U.S. Patent and Trademark office and other countries. All other trademarks are the property of their respective owners. Patents may apply or be pending.

1675 MacArthur Boulevard • Costa Mesa, CA 92626 • Ph: 800/854-4079 or 714/957-7100 • Fax: 714/754-6174

CX 4-channel Spec Sheet - 06/04/08



**RDL**<sup>®</sup>  
Radio Design Labs

SPECIALISTS IN PRACTICAL PRECISION ENGINEERING™

## RACK-UP<sup>®</sup> SERIES Model RU-ADA4D Audio Distribution Amplifier

- Stereo Audio Distribution with 4 Outputs
- Mono Audio Distribution with 8 Outputs
- Front-Panel Input Level Trimmers
- Dual-LED VU Meter for Each Input Channel
- Front-Panel Output Level Trimmers
- Inputs and Outputs on Rear Panel Detachable Terminal Blocks
- Exceptional Audio Quality for the Most Demanding Applications



The RU-ADA4D is part of the group of RACK-UP products from Radio Design Labs. RACK-UPs feature the advanced circuitry for which RDL products are known, combined with accessible user-friendly controls and displays. The ultra compact design permits high-density installations, with *three* products mounted in a single rack unit. Optional brackets permit mounting a RACK-UP module above, below, or in front of any flat surface.

**APPLICATION:** The RU-ADA4D is a four channel stereo audio distribution amplifier with input and output gain adjustments and input level metering. The module may be operated in mono to provide up to eight distributed mono signals. The inputs and outputs are connected on rear-panel detachable terminal blocks.

Each of the two line-level inputs accepts either a balanced or an unbalanced signal. Each input is equipped with a front panel INPUT GAIN trimmer. Input signal levels between -14 dBV unbalanced and +9 dBu balanced may be set to the proper operating level as indicated by a dual-LED VU meter. This assures ample headroom at all normal operating levels. The maximum input level is +25 dBu.

A rear-panel switch selects between stereo and mono operation. In the mono position, input A (left) is used to drive all 8 output channels. When the module is used in a monaural system, only input A must be wired.

Audio outputs are isolated from each other and may be wired balanced or unbalanced. Each of the outputs is provided with a front-panel screwdriver adjusted OUTPUT LEVEL control. Relative to a balanced +4 dBu output level, this gain potentiometer allows an adjustment range from -9 dB to +6 dB. Relative to an unbalanced -10 dBV output, each output potentiometer allows an adjustment from -3 dB to +12 dB.

The RU-ADA4D offers exceptional headroom, very low distortion, excellent crosstalk isolation, wide flat frequency response and extremely low noise with very high common-mode signal rejection. It provides exceptional audio performance for the most critical applications in a professional audio environment.

The RU-ADA4D operates from 24 Vdc connected through a rear-panel detachable terminal block.





**RDL**<sup>®</sup>  
Radio Design Labs

SPECIALISTS IN PRACTICAL PRECISION ENGINEERING™



# RACK-UP® SERIES Model RU-ADA4D Audio Distribution Amplifier

## Installation/Operation



Declaration of Conformity available from [rdlnet.com](http://rdlnet.com).  
Sole EMC specifications provided on product package.  
Specifications are subject to change without notice.

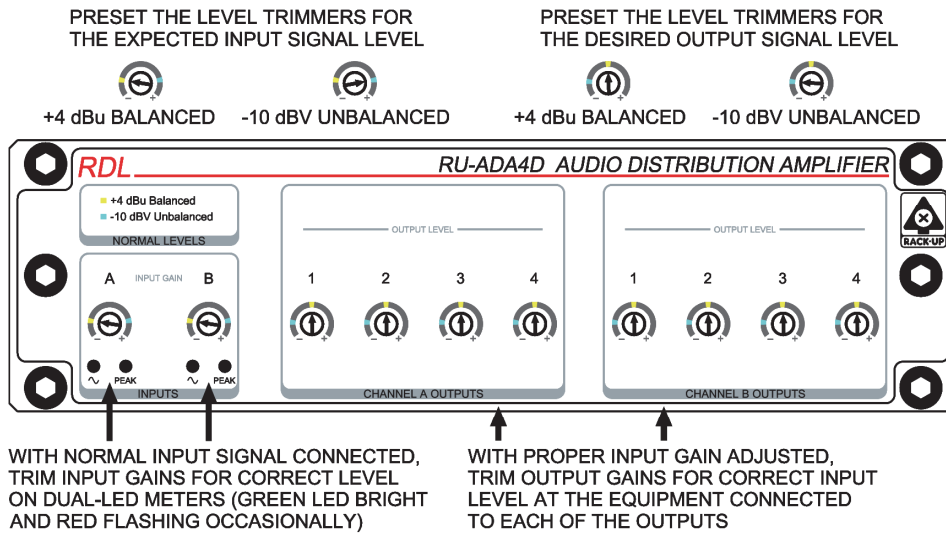

### BALANCED WIRING

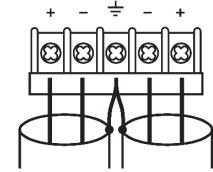

### UNBALANCED WIRING

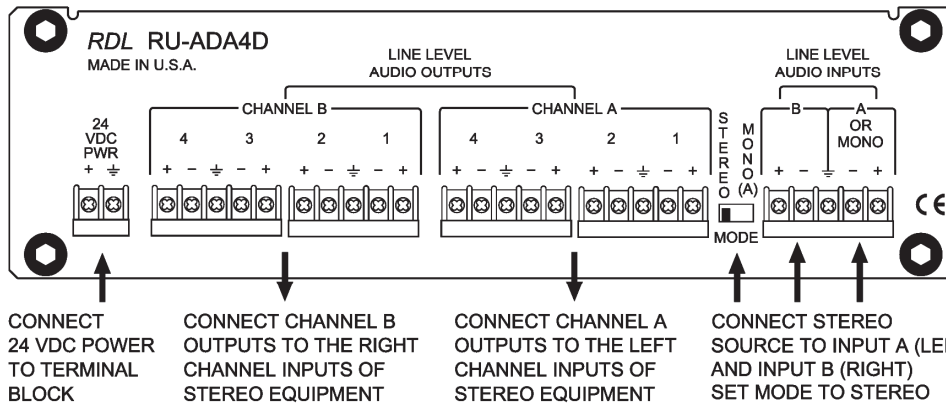
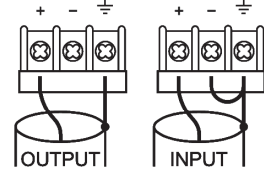

NOTE: IF THE MODE SWITCH IS SET TO MONO, THE MONO SOURCE WILL FEED ALL OUTPUTS.  
CONNECT EACH OUTPUT (CHANNEL A OR B) TO THE INPUT OF MONO EQUIPMENT

### TYPICAL PERFORMANCE

Inputs (2): Stereo (A/left and B/right) on detachable terminal block  
20 kΩ balanced or 10 kΩ unbalanced

Input Impedance: +4 dBu balanced (nominal), +25 dBu maximum;  
-10 dBV unbalanced

Input Level: -5 dB to +15 dB (rel. +4 dBu balanced); -3 dB to +17 dB (rel. -10 dBV unbalanced)

Input Gain Adjustments (2): Dual-LED VU Meter for Input A and Input B

Input Metering (2): Rear-panel switch-selectable (input A feeds all 8 outputs)

Mono mode: Stereo, A (4), B (4) on detachable terminal blocks

Outputs (8): 150 Ω balanced; 75 Ω unbalanced

Output Impedance: +4 dBu balanced (nominal), +24 dBu maximum;  
-10 dBV unbalanced

Output Level: -9 dB to +6 dB (rel. +4 dBu, balanced);  
-3 dB to +12 dB (rel. -10 dBV, unbalanced)

Frequency Response: 10 Hz to 165 kHz (+/- 0.25 dB);  
10 Hz to 35 kHz (+/- 0.01 dB)  
< 0.0025% (20 Hz to 20 kHz)

THD+N: > 20 dB (above +4 dBu input or output)

Headroom: < -92 dB (below +4 dBu output, 20 Hz to 20 kHz)

Noise: < -90 dB (20 Hz to 5 kHz); < -80 dB (5 kHz to 20 kHz)

Crosstalk: > 90 dB (100 Hz)

CMRR: GROUND-REFERENCED,

Power Requirement: 24 Vdc @ 82 mA (idle, nominal), 120 mA (max.)

Ambient Operating Environment: 0° C to 50° C

Case Dimensions: 5.75" (14.6 cm) W x 1.65" (4.18 cm) H x 3.54" (9.0 cm) D;  
3.9" (9.9 cm) D with connectors

Radio Design Labs Technical Support Centers  
U.S.A. (800) 933-1780, (928) 778-3554; Fax: (928) 778-3506  
Europe [NH Amsterdam] (+31) 20-6238 983; Fax: (+31) 20-6225-287





**RDL**<sup>®</sup>  
Radio Design Labs

SPECIALISTS IN PRACTICAL PRECISION ENGINEERING™

## STICK-ON<sup>®</sup> SERIES

### Model ST-SH2

### Stereophonic Headphone Amp

- Stereophonic Headphone Amplifier
- Provision for External Stereo Level Control
- Balanced or Unbalanced Inputs
- Bridge a Line and Feed Headsets
- Amplifier To Drive High or Low Impedance Headsets



The ST-SH2 is part of the group of versatile STICK-ON products from Radio Design Labs. STICK-ONS feature the advanced circuitry for which RDL products are known, combined with unequalled versatility in mounting possibilities. The durable adhesives provided with the ST-SH2 permit permanent or removable mounting. Numerous available mounting accessories, brackets, rack-mount and tabletop chassis are optionally available to facilitate any system design. STICK-ONS are designed, built and rated for continuous duty in professional AV systems.

**FUNCTIONAL DESCRIPTION:** The ST-SH2 is a dual channel headphone amplifier with balanced/unbalanced left (L) and right (R) inputs. Each input is designed to accept an input signal with operating levels between -20 dBV and +8 dBu. A multi-turn gain potentiometer is provided for setting the maximum gain independently for each input channel. Terminals are provided for optional connection of an external audio taper 10 k $\Omega$  potentiometer. Three terminals are used for an external stereo control: Left-channel pot wiper (**LEVEL ADJUST: L**), Right-channel pot wiper (**LEVEL ADJUST: R**), and Ground (common to both pot channels). The output amplifiers can each drive either high or low impedance headphones, producing up to 250 mW into 8  $\Omega$  or 20 Vp-p into 2 k $\Omega$ .

Module operation is from a 24 Vdc ground-referenced power supply.

**TYPICAL APPLICATION:** The ST-SH2 is used in applications requiring headphones of any impedance to be driven from consumer or professional audio sources. For fixed level installations not requiring user volume control, the ST-SH2 is wired to the audio source and to a headphone jack. Frequently, it is desirable to mount a volume knob by the headphone jack. The **LEVEL ADJUST** terminals (L) and (R) may be wired to the respective wipers of a stereo 10 k $\Omega$  potentiometer to provide volume adjustment. It is recommended that the ST-SH2 be located less than 39 in. (1m) from the jack and volume control.

The exceptional low noise (better than 100 dB below operating level), low distortion, audio clarity and excellent crosstalk performance makes this module ideally suited to a wide variety of demanding audio applications. Use this module in conjunction with other RDL modules as part of a high quality, flexible audio/video system.

# STICK-ON<sup>®</sup> SERIES

## Model ST-SH2 Stereophonic Headphone Amp

## Installation/Operation

 Declaration of Conformity available from rdlnet.com.  
Sole EMC specifications provided on product package.  
Specifications are subject to change without notice.

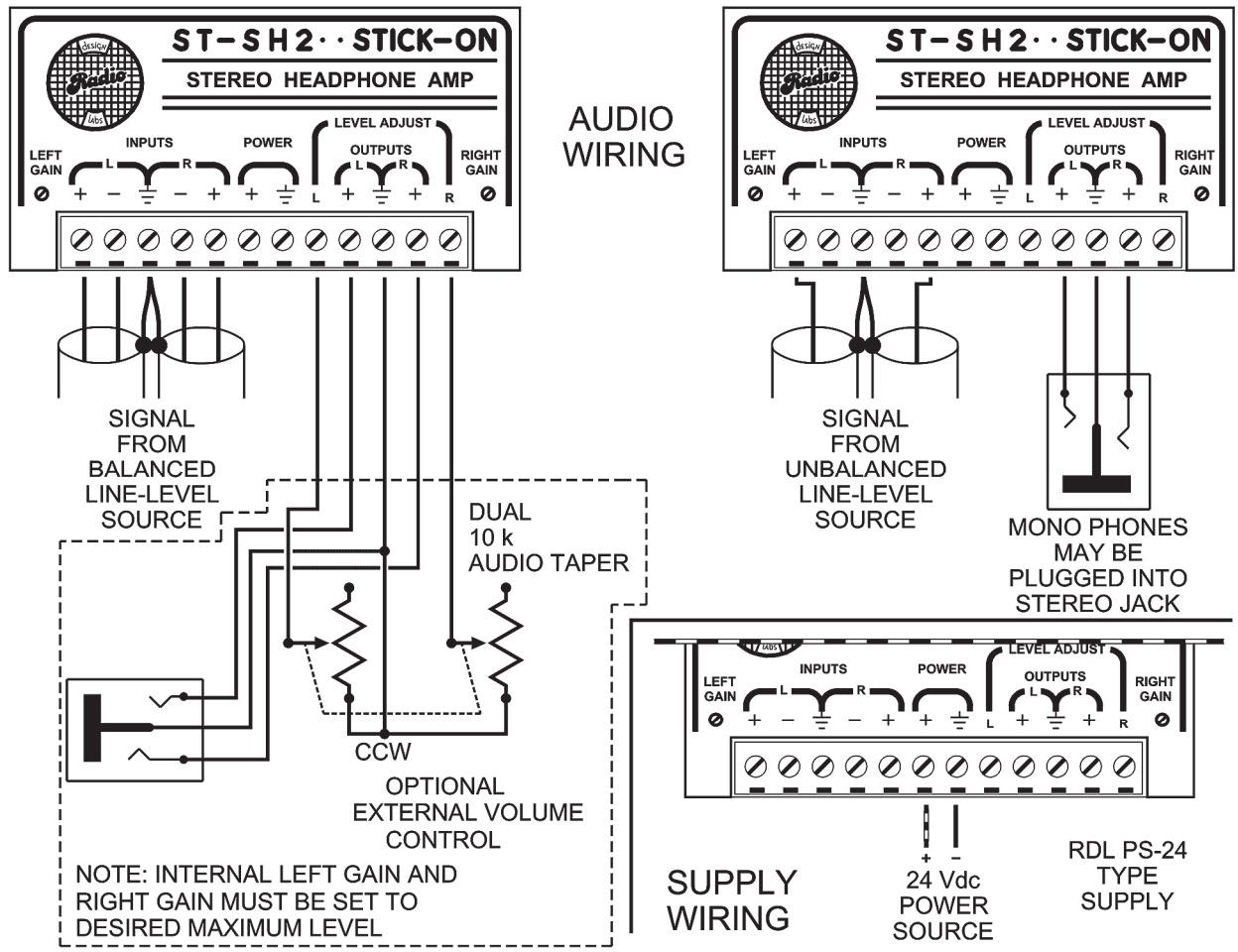

### TYPICAL PERFORMANCE

Input:	10 k $\Omega$ balanced or unbalanced bridging
Input Signal:	-20 dBu (-22 dBV) to +6 dBu (for normal output level: +4 dBu, 100 $\Omega$ ) -10 dBu to +16 dBu (for 250 mW, 8 $\Omega$ output)
Output Load Impedance:	8 $\Omega$ to 5 k $\Omega$ (Drives low or high impedance headphones)
Output Signal (normal rated):	+4 dBu into 100 $\Omega$
Output Signal (maximum):	250 mW into 8 $\Omega$ , 20 Vp-p into 2 k $\Omega$
THD+N:	< 0.005% (0.0015% typical @ 1 kHz)
Frequency Response:	20 Hz to 40 kHz ( $\pm$ 0.25 dB)
Noise:	< -100 dB below normal operating level
Total Dynamic Range:	> 115 dB
Gain:	Adjustable from -2 to 24 dB
CMRR:	> 50 dB at 100 Hz
Crosstalk:	< -65 dB (10 Hz - 20 kHz); < -80 dB @ 1 kHz
Ambient Operating Environment:	0 $^{\circ}$ C to 55 $^{\circ}$ C
Power Requirement:	GROUND-REFERENCED, 24 Vdc @ 200 mA

Radio Design Labs Technical Support Centers

U.S.A. (800) 933-1780, (928) 778-3554; Fax: (928) 778-3506

Europe [NH Amsterdam] (+31) 20-6238 983; Fax: (+31) 20-6225-287

# SHURE®

LEGENDARY  
PERFORMANCE™

Microflex® Wireless Systems

# MICROFLEX® WIRELESS SYSTEMS



Microflex® Wireless microphone systems bring modern design and vivid, lifelike sound to signature boardrooms and AV conferencing environments. This enterprise-scale platform encompasses a system of advanced conferencing products that includes intelligent rechargeable microphone transmitters and charging stations, discreet wireless access point transceivers, flexible audio network interfaces, and comprehensive software tools for remote adjustment and monitoring of system settings.

## Premium Conferencing Audio for Elite Boardrooms

Vivid Lifelike Sound, Versatile Microphone Selection, Discreet Designs, Scalable Solutions

## Networked Digital Wireless for Enterprise-Scale Environments

Dante™ Digital Audio Networking, Ethernet Connectivity, Control System Compatible, Microflex Wireless Control Software

## Intelligent Performance, Simplified Setup & Operation

Advanced Rechargeable Power Management, Automated Frequency Coordination, Encrypted Wireless, Assignable RF output power

## Trusted Shure Experience

Wireless Expertise, Signature Audio, Reliable Product Support

### APPLICATIONS

Boardrooms

Corporate Theaters

AV Conferencing Spaces

Training/Seminar Centers

### PRODUCT HIGHLIGHTS

Vivid, lifelike sound

Stylish, versatile wireless microphone options

Digital audio networking over Ethernet

Microflex Wireless Control Software

AES256 encryption



CommShield®  
Technology

# System Specifications

## Features

- Vivid, lifelike sound: Performance-tested Microflex® microphone elements flawlessly capture full range audio for clear, detailed communication
- Versatile microphone selection: Wireless boundary, gooseneck, bodypack, and handheld models are available to fit any conferencing application
- Discreet designs: With elegant aesthetics and a low-profile footprint, Microflex Wireless systems are designed to install easily and disappear into AV environments
- Scalable solutions: 2, 4 and 8 channel systems can be combined support configurations of up to 40 compatible channels (80 in Europe and select countries). Adjustable power limits enable additional channels to operate in separate rooms
- Dante™ digital audio networking: Integrated solution for transporting low latency, uncompressed audio over standard Ethernet networks
- Ethernet connectivity: All Microflex Wireless networking components connect via Cat5e cable for simplified installation
- Corporate network ready: Connect to corporate networks and third party control systems using standard networking protocols, for remote management and campus-wide implementation
- Microflex Wireless Control Software: Browser-based control software that offers comprehensive remote monitoring and control of all settings and status parameters over the web, a corporate network or an AV local area network
- Control system compatible: Third party control and automation systems (AMX®, Crestron®) are fully compatible with Microflex Wireless, enabling the creation of custom interfaces on touchscreen panels
- Advanced rechargeable power management: Smart lithium-ion rechargeable batteries deliver up to 9 hours of continuous use, enable remote status monitoring while in the charger and provide remaining runtime in hours and minutes while in use via networked control systems
- Automated frequency coordination: Microflex Wireless systems actively scan the available spectrum and coordinate clean, compatible frequencies for every microphone channel. While in use, systems automatically move away from unexpected interference
- Encrypted wireless: Audio transmission is protected by AES-256 encryption - the same secure standard used in top government applications
- Selectable transmit power: Select the appropriate wireless output power per room to optimize spectrum usage, range, and battery life

## Specifications (subject to change)

<b>RF Carrier Frequency Range</b>	USA, Canada, Mexico: 1920–1930 MHz Europe, Asia, Middle East: 1880–1900 MHz
<b>Working Range</b>	50 m (160 ft) Note: Actual range depends on RF power setting and signal absorption, reflection and interference.
<b>Audio Frequency Response</b>	50 Hz – 20 kHz (+1, -3 dB) Note: Dependent on microphone type
<b>Dynamic Range</b>	>99 dB, A-weighted
<b>System Gain</b> <small>(Mic gain @ 0dB to line level output on MXWANI through Dante)</small>	+50 dB
<b>Latency</b>	18 ms, nominal
<b>System Audio Polarity</b>	Positive pressure on microphone diaphragm (or positive voltage on pin 3 of TA4M connector) produces a positive voltage on pin 2 of the ANI (with respect to pin 3 of the low-impedance output).
<b>Radio Transmission</b>	Time Division Multiple Access (TDMA), Gaussian Frequency Shift Keying (GFSK), 365 kHz max. deviation
<b>RF Sensitivity</b>	-87 dBm, minimum
<b>Power</b>	19 dBm (80 mW) maximum, See Frequency Range and Output Power table
<b>Cable Requirements</b>	Cat 5e or higher, shielded, 100 m maximum between network devices
<b>Network Addressing Capability</b>	DHCP, link-local, static
<b>Operating Temperature Range</b>	0°C (32°F) to 49°C (120°F)
<b>Storage Temperature Range</b>	-29°C (-20°F) to 74°C (165°F)

### Frequency Range and Microphone Transmitter Output Power

Band	Frequency Range (MHz)	Region	Power (mW)
Z10	1920 to 1930	USA, Canada, Mexico	Low = 0.63 Medium = 3.16 High = 15.85 Maximum = 79.43
Z11	1880 to 1900	Europe, Asia, Middle East	Low = 0.63 Medium = 3.16 High = 15.85 Maximum = 79.43

**SHURE**<sup>®</sup>  
LEGENDARY  
PERFORMANCE™

# MXW1 Bodypack Transmitter

## Overview

The MXW1 is a hybrid bodypack transmitter compatible with Microflex® Wireless systems. It offers both an integrated omnidirectional microphone and an input jack for connecting an ear-worn or lavalier style microphone. The integrated microphone is perfect for picking up speech while the bodypack is on a lanyard or tucked into a shirt pocket, and a belt clip is included for attachment to clothing.

## Features

- Compact, low-profile design: Fits comfortably into a shirt pocket or attached to clothing
- Integrated omnidirectional mic: Clearly captures full range audio without connecting an external microphone
- External microphone input: For connecting multiple styles of ear-worn or lavalier condenser microphones
- Bi-directional wireless: Enables return channel audio and real time remote control of all wireless microphone settings
- Earphone output: Listen to audio from a return channel for translation, cueing, or program material
- Programmable mute button: Customize local or remote muting behavior per application, with options including push-to-talk, push-to-mute, and external control.
- Standby mode: Enabled remotely during breaks or periods of inactivity to significantly extend battery life when not in use
- Wide working range: Reliable wireless coverage extends up to 160 feet (50 meters)
- Out of range alert: Emits beeping sound when range limit is exceeded
- Wide frequency response: Captures full range audio for clear voice transmission
- Easy transmitter linking: Assign the microphone to an Access Point channel by simply docking it into a Networked Charging Station and pressing “link”
- Encrypted wireless: AES 256-bit encryption for secure transmission.
- Advanced Li-ion batteries: Smart lithium-ion internal batteries provide up to 9 hours of continuous use, charge to full in 2 hours, and enable remote monitoring over the network of remaining runtime and charge status in hours and minutes
- USB charging: Connects to any standard USB power source for “always on” usage



**MXW1**  
Bodypack Transmitter

## Specifications (subject to change)

<b>Gain Adjustment Range</b>	-25 to +15 dB (in 1 dB steps)
<b>Maximum Input Level</b> (Mic gain @ -16 dB)	-9 dBV
<b>Headphone Output</b>	3.5 mm (1/8"), dual mono (will drive stereo phones)
<b>Maximum Headphone Output Power</b> <small>(1kHz @ 1% distortion, peak power, @16Ω)</small>	17.5 mW
<b>Antenna Type</b>	Internal, Spacial Diversity, Linear Polarization
<b>Battery Type</b>	Rechargeable Li-Ion
<b>Battery Life</b>	Up to 9 hours Calculated with a new battery. Runtimes vary depending on battery health.
<b>Charge Connector</b>	USB 3.0 Type A
<b>Housing</b>	Molded Plastic
<b>Recommended Storage Temperature Range</b>	0 °C (32 °F) to 25 °C (77 °F)
<b>Microphone Connector</b>	4-Pin male mini connector (TA4M), See drawing for details
<b>Input Impedance</b> (@ 1 kHz)	>20 kΩ
<b>Internal Microphone</b>	Omnidirectional (20 Hz – 20 kHz)
<b>Dimensions</b>	22 mm x 45 mm x 99 mm (0.9 in. x 1.8 in. x 3.9 in.) H x W x D
<b>Weight</b>	85 g (3.0 oz.) with batteries, without microphone

## Available Models

<b>MXW1/O</b>	MXW bodypack transmitter (without lavalier microphone)
---------------	--------------------------------------------------------

## Optional Accessories

<b>SBC-USB</b>	USB Plug-in Charger
<b>SB901A</b>	Replacement Battery for MXW1, MXW6, and MXW8 Transmitters
<b>See table on right</b>	Lavalier microphone



TA4M Connector

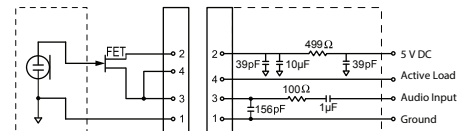

Top view of bodypack



## Lavalier Options

<b>MX150B/O-TQG</b>	Microflex 5mm Subminiature Lavalier, Omnidirectional, Black
<b>MX150B/C-TQG</b>	Microflex 5mm Subminiature Lavalier, Cardioid, Black
<b>MX153B/O-TQG</b>	Microflex Omnidirectional Subminiature Earset, Black
<b>MX153T/O-TQG</b>	Microflex Omnidirectional Subminiature Earset, Tan
<b>MX153C/O-TQG</b>	Microflex Omnidirectional Subminiature Earset, Cocoa
<b>WL183</b>	Microflex 1cm Omnidirectional Lavalier, Black
<b>WL184</b>	Microflex 1cm Supercardioid Lavalier, Black
<b>WL185</b>	Microflex 1cm Cardioid Lavalier, Black
<b>WL93</b>	Omnidirectional Condenser Miniature Lavalier, Black
<b>WCB6B</b>	Countryman, 3mm Subminiature Omnidirectional Lavalier, Black
<b>WCE6B</b>	Countryman, Omnidirectional Rigid Earset Microphone, Black
<b>WCE6T</b>	Countryman, Omnidirectional Rigid Earset Microphone, Tan

# MXW2 Handheld Transmitter

## Overview

The MXW2 is a handheld transmitter compatible with Microflex® Wireless Systems. With lightweight but durable construction and integrated diversity antennas, the MXW2 delivers vivid lifelike sound, intelligent wireless performance, encrypted transmission, and advanced rechargeability for presentation and conferencing applications. Available with trusted Shure microphone cartridges, including the legendary SM58®.

## Features

- Interchangeable microphone cartridges: Available with the SM58®, SM86, Beta® 58A and VP68 signature Shure microphones
- Dual transmit antennas: Maximizes transmission strength depending on hand placement
- Bi-directional wireless: Enables real time remote control of all wireless microphone settings
- Programmable mute button: Customize local or remote muting behavior per application, with options including push-to-talk, push-to-mute, and external control.
- Standby mode: Enabled remotely during breaks or periods of inactivity to significantly extend battery life when not in use.
- Wide working range: Reliable wireless coverage extends up to 160 feet (50 meters)
- Range warning alert: Emits beeping sound when range limit is exceeded
- Easy transmitter linking: Assign the microphone to an Access Point channel by simply docking it into a Networked Charging Station and pressing “link”
- Encrypted wireless: AES 256-bit encryption for secure transmission.
- Advanced Li-ion batteries: Smart lithium-ion internal batteries provide up to 15 hours of continuous use, charge to full in 3 hours, and enable remote monitoring over the network of remaining runtime and charge status in hours and minutes
- USB charging: Connects to any standard USB power source for “always on” usage.



**MXW2**  
Handheld Transmitter

## Specifications (subject to change)

<b>Gain Adjustment Range</b>	-25 to +15 dB (in 1 dB steps)
<b>Maximum Input Level</b> <small>(Mic gain @ -16 dB)</small>	-9 dBV
<b>Antenna Type</b>	Internal, Spacial Diversity, Linear Polarization
<b>Battery Type</b>	Rechargeable Li-Ion
<b>Battery Life</b>	Up to 15 hours Calculated with a new battery. Runtimes vary depending on battery health
<b>Charge Connector</b>	USB 3.0 Type A
<b>Housing</b>	Molded Plastic
<b>Recommended Storage Temperature Range</b>	0 °C (32 °F) to 25 °C (77 °F)
<b>Microphone Capsule</b>	SM58®, SM86, Beta® 58A, VP68
<b>Configuration</b>	Unbalanced
<b>Input Impedance</b> <small>(@ 1 kHz)</small>	>20 kΩ
<b>Dimensions</b>	226 mm x 51 mm (8.9 in. x 2.0 in.) L x Dia. including SM58 microphone capsule
<b>Weight</b>	323 g (11.4 oz.) with batteries, including SM58 microphone capsule

## Available Models

<b>MXW2/SM58</b>	Wireless Handheld Transmitter with SM58® Microphone
<b>MXW2/SM86</b>	Wireless Handheld Transmitter with SM86 Microphone
<b>MXW2/BETA58</b>	Wireless Handheld Transmitter with Beta® 58A Microphone
<b>MXW2/VP68</b>	Wireless Handheld Transmitter with VP68 Microphone

## Optional Accessories

<b>RPW112</b>	Cartridge, Housing Assembly and Matte Grille for Wireless SM58®
<b>RPW114</b>	Cartridge, Housing Assembly and Matte Grille for Wireless SM86
<b>RPW118</b>	Cartridge, Housing Assembly and Matte Grille for Wireless Beta® 58A
<b>RPW124/VP68</b>	Cartridge, Housing Assembly and Matte Grille for Wireless VP68
<b>SBC-USB</b>	USB Plug-in Charger
<b>SB902</b>	Replacement Battery for MXW2 Transmitter

**SHURE**<sup>®</sup>  
LEGENDARY  
PERFORMANCE™



# MXW6 Boundary Transmitter

## Overview

The Shure MXW6 is a boundary microphone transmitter compatible with Microflex® Wireless Systems. With a low-profile design and cardioid or omnidirectional polar pattern options, the MXW6 allows flexible placement with excellent audio capture on any surface in front of one or multiple speakers. All Microflex Wireless transmitters deliver pristine audio quality, intelligent wireless performance, encrypted transmission, and advanced rechargeability for conferencing and presentation applications.

## Features

- Coverage options: Available in cardioid or omnidirectional polar patterns
- Wide frequency response: Full range audio for clear voice transmission
- Microflex capsules: Well known and trusted Microflex sound signature
- Bi-directional wireless: Enables return channel audio and real time remote control of all wireless microphone settings
- Earphone output: Listen to audio from a return channel for translation, cueing, or program material
- Concealed power switch: Prevents accidental powering off
- Programmable mute button: Customize local or remote muting behavior per application, with options including push-to-talk, push-to-mute, and external control
- Encrypted wireless: AES 256-bit encryption for secure transmission
- Wide working range: Reliable wireless coverage extends up to 160 feet (50 meters)
- Out of range alert: Emits beeping sound when range limit is exceeded
- Easy wireless linking: Assign the microphone to an Access Point channel by simply docking it in a Networked Charging Station and pressing “link”
- Advanced Li-ion batteries: Smart lithium-ion internal batteries provide up to 9 hours of continuous use, charge to full in 2 hours, and enable remote monitoring over the network of remaining runtime and charge status in hours and minutes
- Standby mode: Enabled remotely during periods of inactivity to significantly extend battery life when not in use
- Low-battery LED: Visually alerts when there is 30 minutes of charge remaining
- USB charging: Connects to any standard USB power source for “always on” usage



**MXW6**  
Boundary Transmitter

## Specifications (subject to change)

<b>Gain Adjustment Range</b>	-25 to +15 dB (in 1 dB steps)
<b>Maximum Input Level</b> <small>(Mic gain @ -16 dB)</small>	-9 dBV
<b>Headphone Output</b>	3.5 mm (1/8"), dual mono (will drive stereo phones)
<b>Maximum Headphone Output Power</b> <small>(1kHz @ 1% distortion, peak power, @16Ω)</small>	17.5 mW
<b>Antenna Type</b>	Internal, Spacial Diversity, Linear Polarization
<b>Battery Type</b>	Rechargeable Li-Ion
<b>Battery Life</b>	Up to 9 hours Calculated with a new battery. Runtimes vary depending on battery health
<b>Charge Connector</b>	USB 3.0 Type A
<b>Housing</b>	Molded Plastic
<b>Recommended Storage Temperature Range</b>	0 °C (32 °F) to 25 °C (77 °F)
<b>Microphone Capsule</b>	MXW6/O: R183B MXW6/C: R185B
<b>Dimensions</b>	23 mm × 44 mm × 114 mm (0.9 in. × 1.75 in. × 4.5 in.) H × W × D
<b>Weight</b>	108 g (3.8 oz.) with batteries

## Available Models

<b>MXW6/O</b>	Wireless Boundary Transmitter, Omnidirectional
<b>MXW6/C</b>	Wireless Boundary Transmitter, Cardioid

## Optional Accessories

<b>SBC-USB</b>	USB Plug-in Charger
<b>SB901A</b>	Replacement Battery for MXW1, MXW6, and MXW8 Transmitters

**SHURE**<sup>®</sup>  
LEGENDARY  
PERFORMANCE™

# MXW8 Gooseneck Base Transmitter

## Overview

The MXW8 is a gooseneck base transmitter compatible with Microflex® Wireless Systems. With a stylish, contoured design and minimal footprint it complements any conference setting. The MXW8 accepts Microflex gooseneck microphones available in multiple lengths with polar pattern and LED options. All Microflex Wireless transmitters deliver pristine audio quality, intelligent wireless performance, encrypted transmission, and advanced rechargeability for conferencing and presentation applications.

## Features

- Gooseneck options: Compatible with a wide variety of length, LED light ring, and polar pattern variations of Microflex Gooseneck Microphones
- Wide frequency response: Full range audio for clear voice transmission
- Concealed power switch: Prevents accidental powering off
- Bi-directional wireless: Enables return channel audio and real time remote control of all wireless microphone settings including light ring indication
- Earphone output: Listen to audio from a return channel for translation, cueing, or program material
- Programmable mute button: Customize local or remote muting behavior per application, with options including push-to-talk, push-to-mute, and external control
- Encrypted wireless: AES 256-bit encryption for secure wireless transmission
- Wide working range: Reliable wireless coverage extends up to 160 feet (50 meters)
- Out of range alert: Emits beeping sound when range limit is exceeded
- Easy wireless linking: Assign the microphone to an Access Point channel by simply docking it in a Networked Charging Station and pressing “link”
- Advanced Li-ion batteries: Smart lithium-ion internal batteries provide up to 9 hours of continuous use, charge to full in 2 hours, and enable remote monitoring over the network of remaining runtime and charge status in hours and minutes
- Standby mode: Enabled remotely during periods of inactivity to significantly extend battery life when not in use
- Low-battery LED: Visually alerts when there is 30 minutes of charge remaining
- USB charging: Connects to any standard USB power source for “always on” usage



**MXW8**  
Gooseneck Base Transmitter

## Specifications (subject to change)

<b>Gain Adjustment Range</b>	-25 to +15 dB (in 1 dB steps)
<b>Maximum Input Level</b> ( <i>Mic gain @ -16 dB</i> )	-9 dBV
<b>Headphone Output</b>	3.5 mm (1/8"), dual mono (will drive stereo phones)
<b>Maximum Headphone Output Power</b> <small>(1kHz @ 1% distortion, peak power, @16Ω)</small>	17.5 mW
<b>Antenna Type</b>	Internal, Spacial Diversity, Linear Polarization
<b>Battery Type</b>	Rechargeable Li-Ion
<b>Battery Life</b>	Up to 9 hours Calculated with a new battery. Runtimes vary depending on battery health
<b>Charge Connector</b>	USB 3.0 Type A
<b>Housing</b>	Molded Plastic
<b>Recommended Storage Temperature Range</b>	0 °C (32 °F) to 25 °C (77 °F)
<b>Microphone Connector</b>	6-pin connector for Shure MX405/10/15
<b>Configuration</b>	Unbalanced
<b>Input Impedance</b> ( <i>@ 1 kHz</i> )	>20 kΩ
<b>Gooseneck Options</b>	See accessories list
<b>Dimensions</b>	36 mm × 71 mm × 124 mm (1.4 in. × 2.8 in. × 4.9 in.) H × W × D
<b>Weight</b>	193 g (6.8 oz.) with batteries, without microphone

## Available Models

<b>MXW8</b>	MXW gooseneck base transmitter (without gooseneck microphone)
-------------	---------------------------------------------------------------

## Optional Accessories

<b>SBC-USB</b>	USB Plug-in Charger
<b>SB901A</b>	Replacement Battery for MXW1, MXW6, and MXW8 Transmitters
<b>See table on right</b>	Gooseneck microphone

## Gooseneck Microphone Options

<b>MX405LP/C</b>	Cardioid, 5" (12.7 cm), bi-color status indicator, less preamp
<b>MX405LP/S</b>	Supercardioid, 5" (12.7 cm), bi-color status indicator, less preamp
<b>MX405RLP/N</b>	No microphone cartridge, 5" (12.7 cm), light ring, less preamp
<b>MX410LP/C</b>	Cardioid, 10" (25.4 cm), bi-color status indicator, less preamp
<b>MX410LP/S</b>	Supercardioid, 10" (25.4 cm), bi-color status indicator, less preamp
<b>MX410RLP/N</b>	No microphone cartridge, 10" (25.4 cm), light ring, less preamp
<b>MX415LP/C</b>	Cardioid, 15" (38.1 cm), bi-color status indicator, less preamp
<b>MX415LP/S</b>	Supercardioid, 15" (38.1 cm), bi-color status indicator, less preamp
<b>MX415RLP/N</b>	No microphone cartridge, 15" (38.1 cm), light ring, less preamp

**SHURE**<sup>®</sup>  
LEGENDARY  
PERFORMANCE™



# MXWAPT2, MXWAPT4, MXWAPT8 Access Point Transceivers

## Overview

The MXWAPT is a 2- 4- or 8-channel wireless access point compatible with Microflex® Wireless microphone systems. It uses automated frequency coordination to assign clean frequencies to wireless microphones and manages two-way wireless transmission of encrypted audio and control signals. Power to the unit (via PoE) and Dante digital networked audio are both supplied over a single Ethernet cable to simplify installation, and the supplied mounting plate and paintable cover allow discreet placement in boardrooms and conference rooms where low visibility is preferred.

## Features

- Slim profile: Lightweight, discreet unit with paintable cover to match interior room colors and blend into AV environments
- Easy installation: Includes wall/ceiling mounting plate and connects to the system over single Ethernet cable (PoE compatible)
- Plenum rated: Meets rigorous fire safety test standards for installation above drop ceiling tiles
- Scalable configurations: Available in 2, 4 or 8 channel models to fit varying channel count requirements, and multiple units can be combined support configurations of up to 40 compatible channels (80 in Europe and select countries)
- Bi-directional wireless: Provides return channel audio to wireless transmitters and enables real time remote control of all wireless microphone settings
- Automated frequency coordination: Automatically scans available spectrum, coordinates clean frequency assignments, and moves channels away from unexpected interference
- Dante™ digital networked audio: Transports low latency digital audio received from wireless microphones over Cat5e cable to any other Dante-equipped device
- Encrypted wireless: AES 256-bit encryption for secure transmission
- Selectable output power: Optimize spectrum usage by selecting the appropriate wireless output power for the desired operating range
- Diagnostic LEDs: Provide easy visual reference to system activity and indicate power, wireless connection, and network audio status



**MXWAPT**  
Access Point Transceiver

## Specifications (subject to change)

<b>Network Interface</b>	RJ45: Gigabit Ethernet, Dante digital audio
<b>Plenum Rating</b>	UL 2043
<b>Power Requirement</b>	Power over Ethernet (PoE) Class 0, 6.5W
<b>Antenna Type</b>	Internal, Spacial Diversity, Circular Polarization
<b>Housing</b>	Molded Plastic, Cast Zinc
<b>Dimensions</b>	24 mm × 170 mm × 170 mm (1.35 in. × 6.7 in. × 6.7 in.), H × W × D Without mounting plate or cover
<b>Weight</b>	APT8 856 g (1.9 lbs) APT4 845 g (1.9 lbs) APT2 845 g (1.9 lbs) Paintable Cover 85 g (0.2 lbs) Mounting Bracket 68 g (0.15 lbs)

## Available Models

<b>MXWAPT8</b>	8-Channel Access Point Transceiver
<b>MXWAPT4</b>	4-Channel Access Point Transceiver
<b>MXWAPT2</b>	2-Channel Acces Point Transceiver

**SHURE**<sup>®</sup>  
LEGENDARY  
PERFORMANCE™

# MXWANI4, MXWANI8 Audio Network Interface

## Overview

The MXWANI is a 4- or 8-channel Audio Network Interface compatible with Microflex™ Wireless microphone systems that enables easy out-of-the-box system setup with no additional networking hardware required. With per channel analog outputs and a versatile 4-port gigabit switch, it is the central point for connecting and distributing Microflex Wireless systems to conference room AV networks. Front panel controls offer quick adjustments locally, or adjust system settings remotely from a networked PC or Mac through the Microflex Wireless Control Software.



**MXWANI4**  
Audio Network Interface Front Panel

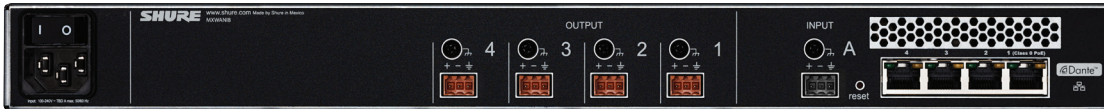

**MXWANI4**  
Audio Network Interface Rear Panel



**MXWANI8**  
Audio Network Interface Front Panel

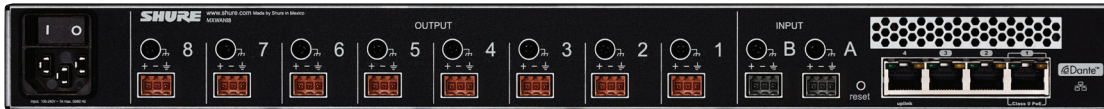

**MXWANI8**  
Audio Network Interface Rear Panel

## Features

- Analog connections: 4 or 8 block connector channel outputs, with 1 or 2 block connector inputs (model dependent)
- Four port gigabit switch: Optimized port configurations for connection to the Access Point Transceiver and Networked Charging Stations, third party control systems, and corporate networks
- Ethernet connectivity: Send audio and control signals over long cable runs of up to 300 feet or anywhere over a corporate network
- Power over Ethernet: Port 1 of the rear panel switch supplies power over Ethernet to the Access Point Transceiver for simplified installation
- Corporate uplink mode: Link to the corporate network for remote control of system settings while keeping audio off the network for security and to reduce bandwidth
- Front panel controls: Mute or solo channels and set input/output levels easily from the front panel
- PC/Mac software control: Access the Microflex Wireless Control Software from a networked computer for input/output levels and port configuration
- Dante™ networking: Transports low latency digital audio received from wireless microphones over Ethernet to any other Dante-equipped device
- Headphone output: Solo audio signal on any channel



# Specifications (subject to change)

<b>Audio Frequency Response</b>	20 Hz to 20 kHz (+1, -1.5 dB)
<b>Dynamic Range</b> <small>(20 Hz to 20 kHz, A-weighted, typical)</small>	Analog-to-Dante: 113 dB Dante-to-Analog: 110 dB
<b>Output Noise</b> <small>(20 Hz to 20 kHz, A-Weighted, typical)</small>	Line: -84.5 dBV Aux: -95.2 dBV Mic: -106.5 dBV
<b>THD+N</b> <small>(20 Hz to 20 kHz@ +4dBu analog input, -10 dBFS digital input)</small>	<0.05%
<b>Polarity</b>	Non-inverting, any input to any output
<b>Dimensions</b>	44 mm × 483 mm × 366 mm (1.7 in. × 19.0 in. × 14.4 in.), H × W × D
<b>Weight</b>	MXWANI4 3.1 kg (6.9 lbs) MXWANI8 3.2 kg (7.1 lbs)
<b>Housing</b>	Steel, Extruded aluminum
<b>Power Requirements</b>	100 to 240 V AC, 50-60 Hz, 1 A
<b>Operating Temperature Range</b>	-18°C (0°F) to 63°C (145°F)
<b>Storage Temperature Range</b>	-29°C (-20°F) to 74°C (165°F)

## Analog Connections - Outputs

<b>Configuration</b>	Active Balanced
<b>Impedance</b>	310 Ω
<b>Clipping Level</b> <small>(minimum)</small>	Line: +26.2 dBV Aux: +16.2 dBV Mic: -3.8 dBV

## Analog Connections - Input(s)

<b>Configuration</b>	Active Balanced
<b>Impedance</b>	10.6 kΩ
<b>Clipping Level</b> <small>(minimum)</small>	Line: +23.8 dBV Aux: +10.8 dBV

<b>Headphone Output</b>	6.35 mm (1/4") TRS, 100 mW, 350 Ω, dual mono (will drive stereo phones) 0 dBV=1 V RMS    0 dBu=0.775 V RMS    0 dBV=2.2 dBu
-------------------------	--------------------------------------------------------------------------------------------------------------------------------

## Digital Signal Processing

<b>AD/DA Converter</b>	24-bit, 48 kHz
<b>Latency</b> <small>(Estimated Nominal, ±0.1 ms)</small>	Analog-to-Dante: 0.21 ms Dante-to-Analog: 0.24 ms + TN TN = Network latency in milliseconds, as set in Dante Controller. Note: Dante network latency is typically associated with the receiving device.

## Networking

<b>Network Interface</b>	Four-Port Gigabit Ethernet Switch, Dante digital audio
<b>Uplink Port (Port 4)</b>	Selectable, blocks multicast traffic
<b>Power over Ethernet (PoE)</b>	Provided on Port 1 to power MXWAPT
<b>Cable Requirements</b>	Cat 5e or higher, shielded, 100 m maximum between network devices
<b>Network Addressing Capability</b>	DHCP, link-local, static

## Available Models

<b>MXWANI8</b>	8-Channel Audio Network Interface
<b>MXWANI4</b>	4-Channel Audio Network Interface

## Optional Accessories

<b>90A20082</b>	Hardware Kit
<b>95B8389</b>	IEC Cable



# MXWNCS2, MXWNCS4, MXWNCS8 Networked Charging Station

## Overview

The MXWNCS is a 2, 4 or 8 port Networked Charging Station compatible with Microflex® Wireless microphone systems. Designed to complement boardroom aesthetics, Networked Charging Stations easily connect between conference room credenzas and AV rack closets over Ethernet via a single Cat5e cable. The front panel displays battery charge in 5 segment LED's, and remaining runtime and charge levels in hours and minutes can be monitored from any networked computer via the control software. Handheld, bodypack and boundary transmitter styles each occupy one docking space while gooseneck bases require two spaces to dock.

## Features

- Versatile microphone docking: Each station accepts all Microflex Wireless transmitters
- Charge status indicators: 5-segment LED's on the unit display charge status individually for every docked microphone
- Remote charge status monitoring: Ethernet connection to the system enables remote monitoring of battery charge status in hours and minutes via the control software or third party control systems
- Easy transmitter linking: Assign docked wireless microphones to channels on an Access Point Transceiver by simply pressing "link"
- Rapid charge times: Reaches 50% charge in one hour and fully charges transmitters in two hours
- Overcharge protection: Smart recharging circuitry safeguards against battery damage and extends life cycles



**MXWNCS2**  
Networked Charging Station shown with MXW2/SM58 and MXW6

## Specifications (subject to change)

<b>Charge Time</b>	MXW1, MXW6, MXW8: 50%=1 hour; 100%=2 hours MXW2: 50%=1.5 hour; 100%=3 hours
<b>Network Interface</b>	10/100 Mbps Ethernet
<b>Power Requirement</b>	15 V DC @ 3.3 A maximum, supplied by external power supply (tip positive)
<b>Housing</b>	Molded Plastic, Cast Zinc
<b>Dimensions</b>	NCS8: 68 mm × 343 mm × 184 mm (2.7 in. × 13.5 in. × 7.25 in.), H × W × D NCS4: 68 mm × 191 mm × 184 mm (2.7 in. × 7.5 in. × 7.25 in.), H × W × D NCS2: 48 mm × 102 mm × 154 mm (1.9 in. × 4.0 in. × 6.1 in.), H × W × D
<b>Weight</b>	NCS8 2.9 kg (6.4 lbs) NCS4 1.7 kg (3.7 lbs) NCS2 0.8 kg (1.8 lbs)



**MXWNCS4**  
Networked Charging Station

## Available Models

<b>MXWNCS8</b>	Networked Charging Station, 8 Port
<b>MXWNCS4</b>	Networked Charging Station, 4 Port
<b>MXWNCS2</b>	Networked Charging Station, 2 Port



**MXWNCS8**  
Networked Charging Station

**SHURE**<sup>®</sup>  
LEGENDARY  
PERFORMANCE™